



Standard for the

Interconnection of Generators

to ATCO Electric's Distribution system

The Alberta Department of Energy sponsored a working group to develop an Alberta Distributed Generation Interconnection Guide (the 'Alberta Guide'). ATCO Electric was a full participant in the development of that Alberta Guide, as were several other Alberta utilities and Power Producers.

ATCO Electric adopts the Alberta Distributed Generation Interconnection Guide (Final July 16, 2002), but modified with specific application notes as identified here. These notes are referenced to the Part and Section of the Alberta guide.

Alberta Guide Part 1

Section 5.0 Operating Requirements:

Some of the requirements the Alberta Guide lists for the operating agreement are contained in ATCO Electric's Terms and Conditions, as approved by the AEUB. The template used by ATCO Electric for the completion of operating agreements will not supercede and will attempt not to duplicate the provisions of the Tariffs, including Terms and conditions.

Alberta Guide Part 2

Section 3.0 General Interconnection and Protection Requirements

3.1 Distribution System:

3.1.3 Power Quality - ATCO Electric's standards for Power Quality are based on IEC standards and are contained in an ATCO Electric document entitled "Distribution System Standard for the addition of New Loads", available on ATCO Electric's web site at www.atcoelectric.com. (Section 3.1.3; p.15 of Guide)

3.2 Generating Facility:

3.2.4 Frequency control - ATCO Electric requires that the generating facility meet the WSCC off-frequency performance requirements as specified in the Guide. Under and over frequency settings tighter than those specified in the WSCC requirements cannot be used unless the frequency relays trip at least an equivalent amount of load along with the generator. (Section 3.2.4; p.18 of Guide)

3.3 Interconnection Facility:

3.3.5 Interconnection grounding - During unbalanced fault conditions on the distribution line, ungrounded generator / transformer configurations can cause damaging over voltages on the distribution system. The DG owner is responsible to provide for a design that limits over voltages. This applies to machine-based generators only, for inverter based see effective grounding info sheet here: <https://electric.atco.com/content/dam/web/for-business/electricity/effective-grounding-and-transient-study-info-sheet-2023.pdf>

This can be accomplished by providing an effective ground reference at the generator site. Following are some ways to achieve effective grounding:

- Use Wye delta transformation (delta on DG side) from DG terminals up to distribution voltage or Customers LV bus (if Wye-wye connected).
- Install a grounding transformer (Zig Zag or equivalent) at DG installation, customer's LV bus or 25 KV bus depending on transformer type
- solidly ground the neutrals of the DG and the transformer windings

If those methods are not suitable, the ATCO Electric may in some cases approve a scheme that directly senses this condition such as negative sequence voltage relaying, and removes the generator from the system in less than 0.1 second.

3.3.8 Over Voltage and Under Voltage Protection

Refer to AESO Trip and Ride-Through Requirements:
<https://www.aeso.ca/assets/DER-Ride-Through-Performance-Recommendations.pdf>
In addition, ATCO requires customer to trip off if an overvoltage of 1.07pu is sustained for 90 seconds

3.3.9 Over Frequency and Under Frequency Protection

Refer to AESO Trip and Ride-Through Requirements:
<https://www.aeso.ca/assets/DER-Ride-Through-Performance-Recommendations.pdf>

3.3.10 Anti-Islanding – The Guide identifies the need for teleprotection signals or ‘other reliable means’ to separate the generator from the distribution system in the event of islanding. Transfer trip schemes must be fail-safe and are addressed in the Guide, section 3.3.12.

The design of systems that rely on the use of local quantities (such as V , f , $\Delta\alpha$) to detect an islanded condition are dependent upon the match between load and generation. When using local quantities, the Guide identifies a need for reliable primary and backup functions using different quantities. ATCO Electric requires at least two independent protection elements to reliably detect the islanded situation and cause the generation to be removed. The detection and removal must take place in 0.6 seconds, to conform with the designed reclosing interval of automatic devices on the distribution line.

Careful study is required of all reasonable contingencies that may give way to islanded operation. ATCO Electric requires that the load in such studies be derived from considering the total range of expected loading through each automatic device in the transmission and distribution systems up to the generating facility. Where load duration curves are available at that device, the minimum loading is to be selected as the 99% probability from a load duration curve for that zone.

Reasonable switching scenarios may further reduce that minimum loading. For example, a switch or switches coincidentally opened elsewhere on the distribution downstream of the automatic device will reduce the load on the device. The addition or removal of shunt capacitance may vary reactive power.

Any overlap of minimum distribution system loading with total generating capacity beyond a device may result in failure of the required number of protective elements to pick up. Where the possible island includes generators capable of frequency and voltage control this indicates that a protective scheme using local quantities will not be acceptable.

Alberta Distributed Generation Interconnection Guide

The Alberta Distributed Generation Interconnection Guide provides guidelines for connecting a generation facility to the Alberta Interconnected Electric System (AIES) via a Wires Owner's distribution system, and assists in determining the technical and operating requirements of the facility.

The Guide was developed by the Alberta Distributed Generation Technical and Policy Committee without regard to whether its adoption may involve patents on articles, materials or processes. Such adoption does not assume any liability to any patent owner, nor does it assume any obligation whatsoever to parties adopting this Guide.

While every precaution has been taken in preparing the Guide, it may contain inadvertent inaccuracies or inconsistencies. The authors assume no liability for errors or omissions, or damages resulting from the use of or reliance upon the information contained herein.

Alberta Distributed Generation Interconnection Guide

In this document...

Part 1 – General Interconnection Information	3
Part 2 – Guide for Generator Interconnection.....	11
Appendices	45

Alberta Distributed Generation Interconnection Guide

Part 1 – General Interconnection Information

In this part...

1.0	Introduction	4
2.0	Terms and Definitions	5
3.0	Responsibilities	7
4.0	Metering Requirements.....	9
5.0	Operating Requirements.....	10

1.0 Introduction

1.1 Intent

The intent of the Alberta Distributed Generation Interconnection Guide (hereinafter referred to as “the Guide” or “this Guide”) is to:

1. Inform and provide guidelines for anyone wishing to connect a generation facility to the AIES via a Wires Owner’s distribution system; and
2. Assist operators, technical staff, consultants and contractors in determining the technical and operating requirements of the facility.

This Guide does **not**:

3. Establish commercial or cost-sharing agreements. Each Wires Owner will have approved tariffs, including terms and conditions and electric service agreements for Distributed Generation (DG) and normal or standby consumption at the site. The DG Owner is encouraged to review its commercial obligations at the time of application.
4. Provide guidelines for connecting to the system at voltages above 25kV. For information on connecting directly to the transmission system, see *Technical Requirements for Connecting to the Alberta Interconnected Electric System Transmission System* at the Transmission Administrator's web site at www.eal.ab.ca.

For a complete description of the electric power industry in Alberta under the Electric Utilities Act, please refer to the Alberta Energy website, www.energy.gov.ab.ca/electric.

1.2 Guiding Principles

This Guide was developed in accordance with the following principles:

1. The interconnection process must provide competitive, fair and equitable access for all DG Owners.
2. The interconnection must not create a safety hazard to other customers, the public or operating personnel.
3. The interconnection must not compromise the reliability or restrict the operation of the electric system.
4. The interconnection must not degrade power quality below acceptable levels.

Part 1:

General Interconnection Information

2.0 Terms and Definitions

The following terms are defined to assist understanding of Distributed Generation:

This term ...	Is defined as ...
Accredited Certification Organization	An organization that has been accredited by the Standards Council of Canada to operate a certification program for electrical equipment, such as the Canadian Standards Association (CSA).
AECUC	The Alberta Electrical and Communication Utility Code.
AEUB	The Alberta Energy and Utilities Board.
AIES	The Alberta Interconnected Electric System.
Bi-Directional Meter	A meter that measures real and reactive power and energy in both directions.
CEA	The Canadian Electricity Association.
CEC	The Canadian Standards Association's C22.1-98 Safety Standard for Electrical Installations Part 1, also known as the Canadian Electrical Code.
CSA	The Canadian Standards Association.
Distributed Generation or Distributed Generator (DG)	Unregulated electric generators connected to a distribution system through the Point of Common Coupling (PCC).
DG Owner	The entity which owns or leases the Distributed Generation facilities.
Distribution System	Any power line facilities under the operating authority of the Wires Owners. Distribution power line facilities generally operate at or below voltages of 25kV nominal, line to line.
Electric Utilities Act	Legislation passed in the Province of Alberta that creates a deregulated market for the generation of electric energy.
Exporter	An entity which sells electric energy produced within the Province of Alberta to buyers outside the province.
Generator	A device that produces AC power. In the case of inverters, the document uses the term Generator to refer to the AC inverter, not the DC source.
IEEE	The Institute of Electrical and Electronics Engineers, Inc.
Importer	An entity which sells electric energy produced outside the Province of Alberta to buyers within the province.
Interval Meter	A meter that measures transmission of electric energy and stores data in 15-minute intervals.
Island	A condition in which a portion of the Wires Owner's system which is electrically separated from the rest of the Wires Owner's system is energized by one or more distributed generators.

Part 1:

General Interconnection Information

This term ...	Is defined as ...
Load Flow Study	A steady-state computer simulation study of the voltages and currents on the electric system.
Load Settlement Agent	The entity responsible for allocating energy to and from the distribution system. The Wires Owners are assigned this responsibility.
Operating Authority	The individual within the Wires Owner's organization and within the DG Owner's organization who is responsible for the safe and orderly operation of electric system facilities.
Parallel Operation	The operation of a generation facility while connected to an electric power grid in such a way that both the grid and the generation facilities supply electric power to the loads at the same time.
Point of Common Coupling (PCC)	The point at which the Wires Owner's facilities are connected to the DG Owner's facilities or conductors, and where any transfer of electric energy between the DG Owner and the Wires Owner takes place.
Power Pool	The market for all electric energy bought or sold in Alberta; the entity through which DG Owners sell their electric energy.
Power Pool Participant	An entity which has executed an agreement with the Power Pool of Alberta for the sale or purchase of electric energy.
Safety Codes Act	The Alberta Safety Codes Act and Alberta regulations under that Act.
Stabilized	The state of the distribution system after voltage and frequency has returned to normal range for a period of at least five minutes (or another period of time, as coordinated with the Wires Owner) following a disturbance.
System Controller	A provincially appointed authority responsible for dispatching load and generation of the AIES in real time.
Tariffs	Published rates, including terms and conditions and electric service agreements for the sale of electric energy and energy services regulated by the AEUB.
Telemetry	The transmission of metering data using telecommunication systems.
Transmission Administrator (TA)	A provincially appointed authority responsible to provide access to the province-wide transmission system. The TA's role is to provide transmission system access service on the AIES in a manner that gives all eligible persons wishing to exchange electric energy through the Power Pool of Alberta a reasonable opportunity to do so.
Transmission System	Any power line facilities under the authority of the Transmission System Owners. Transmission power line facilities generally operate at voltages above 25kV nominal, line to line.
Visible-Break Disconnect	A switch or circuit breaker by means of which the generator and all protective devices and control apparatus can be simultaneously disconnected under full load entirely from the circuits supplied by the generator. All blades or moving contacts must be connected to the generator side, and the design of the disconnect must allow adequate visible inspection of all contacts in the open position.
Wires Owner	The utility owning the distribution system.
WSCC	The Western Systems Coordinating Council.

3.0 Responsibilities

Refer to Appendix A for a block diagram of the approval process for connecting a generation facility to a Wires Owner's distribution system.

3.1 DG Owner Responsibilities

The DG Owner is responsible to:

- Become a Power Pool Participant and comply with any Power Pool requirements (unless all energy produced at the site is to be consumed at the site);
- Provide technical information to the Wires Owner and to the Transmission Administrator, as specified in Appendix B;
- Design, install, operate and maintain the interconnection facility:
 - Ensure all necessary designs and drawings are signed and stamped by a licensed, professional engineer;
 - Have equipment certified by an accredited certification organization; and
 - Verify that the installation conforms to the current edition of Part I of the CEC;
- Pay the costs of interconnection, in accordance with the commercial terms established by the Wires Owner;
- Obtain all required permits and licenses:
 - Ensure that the local inspection and Safety Codes Act enforcement authorities accept the installation, or that the installation falls under the jurisdiction of an accredited corporation under the Safety Codes Act;
 - Before commissioning and commencing parallel operation, obtain the approval of the Wires Owner and establish a Joint Operating Agreement with the Wires Owner, similar to the generic Joint Operating Agreement provided in Appendix C, covering the technical and operating requirements;
 - Obtain AEUB approval and order to connect, and provide the AEUB approval and order numbers to the Wires Owner (AEUB approval requires a Joint Operating Agreement to be in place between the DG Owner and the Wires Owner);
- Obtain written approval from the Wires Owner before commencing parallel operation and before making any modification to the generation facility;
- Ensure metering requirements are met (see section 4.0); and
- Negotiate the timing and any testing requirements for the commissioning process with the Wires Owner, and if needed, with the Transmission Administrator and/or the System Controller.

3.2 Wires Owner Responsibilities

The Wires Owner is responsible to:

- Carry out load flow studies within a reasonable period;
- Prepare a Joint Operating Agreement with the DG Owner, similar to the generic Joint Operating Agreement provided in Appendix C;
- Prepare a commercial agreement to address cost recovery;
- Inform the DG Owner of the Wires Owner's current standards and practices, as they relate to the interconnection;
- Ensure metering requirements are met (see section 4.0); and
- Provide the DG Owner with the information specified in Appendix D.

4.0 Metering Requirements

Both the DG Owner and the Wires Owner must meet requirements related to metering.

The DG Owner is required to:

- Install an electric meter to measure active energy and reactive energy flowing *out of* the generation facility *to* the distribution system. The Wires Owner retains the right to obtain this data for internal use.

The Wires Owner is required to:

- Install an electric meter to measure power, active energy and reactive energy flowing *from* the distribution system *into* the generation facility. The DG Owner retains the right to obtain this metering data for internal use.

As agreeable between the parties, one physical bi-directional meter may be used to fulfill the requirements of both parties.

Metering service companies are available in Alberta. These include distribution Wires Owners, as well as independent metering companies. Measurement Canada is responsible for testing and certification of meters.

5.0 Operating Requirements

5.1 Operating Authority

The Wires Owner and the DG Owner must each identify, by name or by job title, the individual within their organizations who is their “Operating Authority.” The Operating Authority is responsible to establish operating procedures and standards within each organization.

The Operating Authority negotiates and signs the Joint Operating Agreement described in section 5.3. This individual also ensures that the Operator in Charge (see below) is competent to operate their respective system and aware of the provisions of any other operating agreements and any regulations that may apply.

5.2 Operator in Charge

The Wires Owner and the DG Owner must each identify the individual, by name or by job title, who is the “Operator in Charge” of their facilities and operates their portion of the interconnection facility. This individual must be familiar with the Joint Operating Agreement, and also aware of the provisions of any other operating agreements and any regulations that may apply. The Operating Authority and the Operator in Charge may be the same person.

5.3 Joint Operating Agreement

A Joint Operating Agreement must be established between the Wires Owner and the DG Owner to provide for the safe and orderly operation of the interconnection facility. The Agreement must include, but is not necessarily limited to, the following:

- A high-level technical description of the DG Owner’s generation facility, equipment and protection.
- A high-level technical description of the Wires Owner’s distribution system facilities and protection.
- A description of how the generation facility will operate (e.g., parallel or islanded).
- The DG Owner’s intent in operating the generation facility (e.g., sales, demand reduction).
- The name, title and telephone number(s) of the Operating Authority and the Operator in Charge for each party to the Agreement.
- Provision for the Wires Owner to disconnect the generation facility if it fails to meet technical and/or power quality requirements, or if the operation of the generation facility is or may become dangerous to life or property.
- Reference to safety procedures for joint work.
- Identification of responsibility for maintaining current operating information.
- Isolation procedures for work on the facilities.
- Notification requirements, if required before synchronization.
- Any control setting parameters that could affect the interconnection (e.g., voltage and frequency).
- The approval of both the Wires Owner and the DG Owner.

A generic Joint Operating Agreement is provided in Appendix C.

Alberta Distributed Generation Interconnection Guide

Part 2 – Guide for Generator Interconnection

In this part...

1.0 Purpose.....	12
2.0 Limitations	13
3.0 General Interconnection and Protection Requirements.....	14
4.0 Construction.....	30
5.0 Metering	31
6.0 Inspection	33
7.0 Testing.....	34
8.0 Data Requirements.....	38
9.0 Marking And Tagging.....	39
10.0 Maintenance	40
Tables	41

1.0 Purpose

The second part of this Guide establishes the criteria and technical requirements for interconnecting generation facilities with distribution systems (25kV or lower). Specifically, it addresses the performance, operation, testing, safety considerations and maintenance requirements of the interconnection.

These requirements cover a broad spectrum of interests. Interconnecting generation facilities to a distribution system may change the system and its response. Attaining a technically sound and robust interconnection mandates diligence on the part of everyone involved, including designers, manufacturers, users, owners and operators of both the generation facilities and the distribution systems. All of the above-mentioned groups need to reach a cooperative understanding of and meet the requirements established herein.

This Guide was developed with reference to international standards, such as the IEEE Standard P1547 DRAFT Standard for Distributed Resources Interconnected with Distribution Systems. It is subject to regular review and revision, as necessary to conform to evolving Alberta and international standards, such as those developed by the IEEE.

This Guide is not a design handbook. Anyone considering development of a generation facility intended for interconnection to a distribution system should engage the services of individuals qualified to provide design and consulting services for electrical interconnection facilities.

2.0 Limitations

The criteria and requirements established by this Guide are applicable to all DG technologies and to the primary and secondary voltages of the distribution systems. Installation of DG facilities on the radial primary and secondary distribution systems is the main focus of this version, although network distribution systems are considered. For this version, the requirements must be met at the Point of Common Coupling (PCC), although the protective devices may not necessarily be located at that point.

This Guide establishes the **minimum** requirements for the interconnection. Additional requirements may need to be met by both the DG Owner and the Wires Owner to ensure that the final interconnection design meets all local and national standards and codes, and that the design is safe for the intended application. The Guide does not address any liability provisions agreed to elsewhere by both parties in a commercial agreement, or through tariff terms and conditions.

3.0 General Interconnection and Protection Requirements

The DG Owner's generation and interconnection facilities must meet all applicable national, provincial and local construction and safety codes. See Appendix E for a complete listing of commonly used codes and standards.

Anyone may operate a 60 Hertz, three-phase or single-phase generation facility, in parallel with the Wires Owner's distribution system and in accordance with the Joint Operating Agreement established with the Wires Owner, provided the requirements of this Guide are met or exceeded.

The DG Owner is required to install, operate and maintain in good order and repair at all times, in conformity with good electrical practice, the equipment required by this Guide for the safe parallel operation with the Wires Owner's distribution system.

The following three sections, 3.1, 3.2, and 3.3, define the technical requirements for the distribution system, the generation facility and the interconnection facility respectively. These requirements promote safe operation and minimize the impact of the interconnection to the Wires Owner's distribution system and its other customers.

This Guide is not intended to provide protection for the DG Owner's generation facility. It is the responsibility of the DG Owner to protect their facility in such a manner that distribution system outages, short circuits or other disturbances, including excessive zero sequence currents and ferroresonant over-voltages, do not cause damage. The DG Owner's protective equipment must also prevent excessive or unnecessary tripping that could affect the reliability of the distribution system or power quality to other customers.

Refer to Tables 1, 2 and 3 and Appendices F and G for interconnection protective function requirements.

3.1 Distribution System

3.1.1 System Frequency

The AIES operates at 60 Hertz (Hz) Alternating Current (AC). Frequency variations are typically 59.7 Hz to 60.2 Hz for small contingencies that cause modest disturbances, but do not noticeably disrupt the AIES or its connection to the Western System.

Variations of 58 Hz to 61 Hz or greater can occur for larger contingencies, for example if a portion of the AIES is required to be islanded.

3.1.2 Voltage Regulation

CSA Standard CAN3 C235 83: Preferred Voltage Levels for AC Systems 0 to 50,000V provides general guidance as to appropriate performance.

3.1.3 Power Quality

All interconnected equipment must comply with the Wires Owner's standards for power quality.

The following industry standards may provide guidance as to appropriate performance:

- **Voltage Flicker** - IEEE Std. 519-1992 IEEE Recommended Practices and Requirements for Harmonic Control in Electrical Power Systems.
- **Harmonics** - Wires Owner's Guide for the Connection of Non-Linear Load.

3.1.4 Voltage Unbalance

Distribution systems are typically three-phase systems incorporating single-phase distribution taps. The voltage unbalance on a distribution system under normal operating conditions may reach three per cent, due to the unbalanced loading and single-phase regulation. Voltage unbalance will be calculated using the following formula, as derived from NEMA MG1-1993 14.35:

Unbalance (%) = 100 x (deviation from average) / (average).

3.1.5 Fault Levels

Fault levels and maximum allowable fault levels vary significantly through a distribution system and must be considered in the design of the interconnection. Fault levels and X/R ratios must be evaluated for the equipment selected.

3.1.6 System Grounding

Distribution systems are typically operated as effectively (solidly) grounded and Wye-connected at the source substation bus. Other configurations are occasionally found.

Distribution system grounding must conform to the AECUC (formerly the Alberta Electrical and Communication Utility System Regulation 44/1976, or future amendments).

3.1.7 Fault and Line Clearing

To maintain the reliability of the distribution system, the Wires Owner uses automatic re-closing. The DG Owner must take this

Part 2:

Guide for Generator Interconnection

into consideration when designing generator protection schemes to ensure the generator is disconnected from the Wires Owner's system prior to the automatic re-close of breakers. The DG Owner may reconnect when the Wires Owner's system is stabilized.

To enhance reliability and safety, with the Wires Owner's approval the DG Owner may employ a modified relay scheme with tripping or blocking using communications equipment between the DG facility and distribution system facilities.

3.2 Generation Facility

3.2.1 Mitigation of Adverse Effects

Interconnecting distributed generation can adversely affect the electric service to existing or future customers. The DG Owner must work with the Wires Owner to mitigate any adverse affects.

If a generation facility is affecting customers adversely, the Wires Owner may disconnect it until such time as the concern has been mitigated. The DG Owner is responsible for any costs incurred as a result.

3.2.2 Synchronism

Any generation facility that can create an AC voltage while separate from the electric system must have synchronization facilities to allow its connection to the electric system.

Inverter-type, voltage-following equipment that cannot generate an AC voltage while separate from the electric system does not require synchronization facilities; nor do induction generators that act as motors during start-up, drawing power from the electric system before generating their own power.

The DG Owner is responsible to synchronize and maintain synchronization to the Wires Owner's system. The Wires Owner's system cannot synchronize to the generation facility. A proposed synchronizing scheme must be submitted and outlined in the Joint Operating Agreement and attachments.

Distribution and transmission systems typically allow for automatic re-closing of electrical circuits after a variable time delay. The DG Owner is responsible for protecting their own facility from the impacts of such re-closing.

Generators can automatically restart following automatic re-closing of distribution system equipment, if agreed to by the Wires Owner. Generators that automatically restart must have a time delay on restart, adjustable up to 60 minutes or as agreed to by the Wires Owner. The Wires Owner will coordinate the settings of generator restart time delays so that generators on any feeder restart in staggered order.

3.2.3 Voltage Regulation and Power Factor

Part 2: Guide for Generator Interconnection

The DG Owner is responsible to ensure that the voltage levels at the PCC are maintained within the guidelines prescribed by the Wires Owner and/or are at least equal to the voltage levels at all feeder load conditions, prior to the interconnection.

Synchronous generators connected to the distribution system must be equipped with excitation controllers capable of controlling voltage. The generator-bus voltage setpoint must be stable at and adjustable to any value between 95 per cent and 105 per cent so that the Wires Owner can maintain CSA voltage limits on the distribution system.

Induction generators do not have voltage or reactive power control and consume reactive power (VAR). Therefore, the generator must provide reactive compensation to correct the power factor to ± 0.90 at the PCC, unless other terms are negotiated with the Wires Owner.

Inverter-type generating equipment can control the power factor over a wide range, typically ± 0.75 . An inverter-type generator connected to the distribution system must be capable of adjusting the power factor in the range of ± 0.9 . The DG Owner may operate outside that range by agreement with the Wires Owner.

The Wires Owner will define voltage and reactive power control requirements on a project-by-project basis. Together, the Wires Owner and the DG Owner must identify the exact transformer ratio to allow optimum voltage regulation on the system, and determine if an on-load tap-changer is needed.

In order to coordinate with its existing voltage control devices, the Wires Owner may require the generator to operate in a power factor control mode (i.e., within a constant power factor setpoint range). The voltage/ power factor regulator must be capable of controlling the power factor of the generator between $+0.90$ and -0.90 . The Wires Owner will determine the actual setpoint between these limits.

In power factor control mode, the voltage regulator must have a voltage override that causes it to reduce excitation if the voltage at the PCC exceeds an upper limit to be specified by the Wires Owner. The normal upper limit is 105 per cent of nominal; however, the voltage regulator must have provision to adjust this upper limit to between 100 per cent and 110 per cent of nominal. The voltage regulator must also have provision for a time delay between sensing an excursion of the upper voltage and initiating control action. The power factor control equipment must have provision to allow for the adjustment of this time delay between 0 and 180 seconds. The Wires Owner will specify the required time delay.

3.2.4 Frequency Control

Part 2:

Guide for Generator Interconnection

An interconnected generation facility must remain synchronously connected for frequency excursions, as identified in this Guide and the table below.

For generators connected to the AIES, islanded operations are not allowed (see section 3.3.10). Generators **not** connected to the AIES that serve remote isolated systems must be capable of controlling the frequency of the system to between 59.7 Hz to 60.2 Hz for normal operation. Under-frequency and over-frequency relaying that automatically disconnects generators from the AIES must not operate for frequencies in the range of 59.5 to 60.5 Hz.

The frequency of the electric system is controlled by all synchronous generator governor systems that connect to the electric system. Such governor systems respond automatically to changes in system frequency to prevent further deviation.

Synchronous generators and other generators with stand-alone capability and capacity of 10 MW or more must have a speed droop governor. The droop setting of the governor must be five per cent, and the governor system must be operated at all times so that it is free to respond to system frequency changes. If a five per cent setting is not possible, the DG Owner must obtain approval from the Transmission Administrator for some other droop setting.

In accordance with the Transmission Administrator and WSCC off-frequency requirements, generators connected to the grid that protect for off-nominal frequency operation should have relaying protection that accommodates, as a minimum, under-frequency and over-frequency operation for the time frames specified in the following table:

Under Frequency Limit	Over Frequency Limit	Minimum Time
60.0-59.5 Hz	60.0-60.5 Hz	N/A (continuous operating range)
59.4-58.5 Hz	60.6-61.5 Hz	3 minutes
58.4-57.9 Hz	61.6-61.7 Hz	30 seconds
57.8-57.4 Hz		7.5 seconds
57.3-56.9 Hz		45 cycles
56.8-56.5 Hz		7.2 cycles
less than 56.4 Hz	greater than 61.7 Hz	Instantaneous trip

Systems with generators that do not meet the above requirements must automatically trip load to match the anticipated generation loss, at comparable frequency levels.

3.2.5 Voltage Unbalance

Any three-phase generation facility must have a phase-to-phase voltage unbalance not exceeding one per cent, as measured both with no load and with balanced three-phase loading. Voltage unbalance is calculated using the following formula, as derived from NEMA MG1-1993 14.35:

$$\text{Unbalance (\%)} = 100 \times [(\text{deviation from average})/(\text{average})].$$

Single-phase generators must not adversely unbalance the three-phase system. When they are connected in multiple units, an equal amount of generation capacity must be applied to each phase of a three-phase circuit, and the group of generators must maintain balance when one unit trips or begins generating before or after the others.

A single one-phase generator may be connected alone only if it does not cause voltage unbalance on the distribution system in excess of two per cent.

3.2.6 Resonance and Self-Excitation of Induction Generators

- A) The DG Owner should consider resonance in the design of the generation facility, as certain resonance can cause damage to existing electrical equipment, including the electrical equipment of the DG Owner. Engineering analysis by the DG Owner should be a part of the design process to evaluate the existence of, and to eliminate the harmful effects of:
 - a) ferroresonance in the transformer (Appendix H, Note 1);
 - b) sub-synchronous resonance due to the presence of series capacitor banks (Appendix H, Note 2); and
 - c) resonance with other customers' equipment due to the addition of capacitor banks to the distribution system (Appendix H, Note 3).
- B) In the event that an induction generator is used by DG Owner, the adverse effects of self-excitation of the induction generator during island conditions must be assessed and mitigated. The intent is to detect and eliminate any self-excited condition (Appendix H, Note 4.)
- C) The engineering analysis of resonance and the assessment of the self-excitation effects of induction generators must be submitted to the Wires Owner for approval or further evaluation.

3.3 Interconnection Facility

3.3.1 Safety

Safety of personnel, the public and equipment is of primary concern in the design of the interconnection facility.

3.3.2 Point of Common Coupling (PCC)

The PCC must be identified in the design and on the Single Line Diagram. The Wires Owner will coordinate the design, construction, maintenance and operation of the facility on the distribution side of the PCC. The DG Owner is responsible to coordinate the design, construction, maintenance and operation of the facility on the generation side of the PCC. All voltage and frequency parameters specified in this section must be met at the PCC unless otherwise stated.

The DG Owner is responsible for any incremental costs to the transmission/distribution systems caused by the interconnection. The Wires Owner will carry out the engineering, design and construction required for its installation, and charge those costs back to the DG Owner. Ongoing O&M costs incurred on the distribution feeder side will also be recovered by the Wires Owner.

3.3.3 Point of Disconnection

The disconnect switch can be located on the high or low voltage side of the interconnection transformer. When the interconnection involves three-phase generators, the disconnect switch must be gang operated to simultaneously isolate all three phases.

High Voltage Disconnect Switch

The disconnect switch on the distribution side of the interconnection transformer (e.g., 25 kV airbreak) must be installed, owned and maintained by the Wires Owner.

Low Voltage Disconnect Switch

The disconnect switch on the generation side of the interconnection transformer must be installed, owned and maintained by the DG Owner.

The disconnect switch must be a manual, visible-break disconnect that provides safe isolation for the Wire Owner's personnel from the generators and all other possible customer sources of power. Appendices F and G show sample configurations.

All low voltage disconnect switches must:

- Be adequately rated to break the connected generation/load;

Part 2: Guide for Generator Interconnection

- Be located within five meters (horizontal) of the PCC, unless otherwise approved by the Wires Owner;
- Provide a direct, visible means to verify contact operation;
- Allow simultaneous disconnection of all ungrounded conductors of the circuit;
- Plainly indicate whether the switch is in the “open” or “closed” position;
- Be lockable in the “open” position;
- Be capable of being energized from both sides;
- Be readily accessible to the Wires Owner operating personnel;
- Be externally operable without exposing the operator to contact with live parts;
- Be capable of being closed without risk to the operator when there is a fault on the system;
- Be labeled with the Wires Owner’s switch number;
- Meet all applicable CSA Part II standards and all applicable codes; and
- Undergo annual inspections and maintenance.

If the site interconnects multiple generators, one disconnect switch must be capable of isolating all of the generators simultaneously. There may be other means of meeting this requirement; however, the Wire’s Owner’s approval must be obtained before using other means.

The DG Owner must follow the Wires Owner’s switching, clearance and tagging procedures. The Wires Owner is responsible to instruct the DG Owner in this regard.

3.3.4 Phasing

Phasing is not standardized across distribution systems. Therefore, the phase sequence and the direction of rotation must be coordinated between the Wires Owner and the DG Owner.

3.3.5 Interconnection Grounding

Grounding configurations must be designed to provide:

- A solidly grounded distribution system;
- Suitable fault detection to isolate all sources of fault contribution, including the generator, from a faulted line or distribution facility;
- A circuit to block the transmission of harmonic currents and voltages; and
- Protection of the low voltage side from high fault current damage.

The preferred configuration is a Delta connection on the DG Owner's side of the transformer, and a grounded Wye configuration on the Wires Owner's side of the transformer. If this configuration is not possible, the configuration chosen must still address the above concerns. The winding configuration for DG interconnection transformers should be reviewed and approved by the Wires Owner.

3.3.6 Interrupting Device Ratings

The design of the generation facility must consider the fault contributions of both the distribution system and the generation facility itself, to ensure that all circuit fault interrupters are adequately sized. The Wires Owner will inform the DG Owner of the present and anticipated future fault contribution from the interconnected electric system.

3.3.7 Phase and Ground Fault Protection

The DG Owner must install protective devices to detect and promptly isolate the generation facility for faults occurring either in the generation facility itself or on the distribution system. "Virtual devices" (i.e., computer or programmable-logic controller systems) are acceptable provided they meet standard utility practice for system protection and they have been type tested and approved by an independent testing laboratory.

The protective devices in the generation facility must fully coordinate with the protective relays on the distribution system unless otherwise agreed. The DG Owner must calculate the protective device settings and submit the relay characteristics and settings to the Wires Owner for review and approval.

The generation facility must be able to detect the following situations and isolate itself from the distribution system:

- A short circuit between any phase(s) and ground.
- A short circuit between phase(s).
- Loss of any phase(s).

Part 2:

Guide for Generator Interconnection

3.3.8 Over-Voltage and Under-Voltage Protection

The DG Owner must operate its generation facility in such manner that the voltage levels on the Wires Owner's system are in the same range as if the generation facility was not connected.

The DG Owner must install necessary relays to trip the circuit breaker when the voltage, measured phase-to-ground, is outside predetermined limits. Under-voltage relays should be adjustable and should have a settable time delay to prevent unnecessary tripping of the generator on external faults. Over-voltage relays should be adjustable and may be instantaneous.

The DG Owner's interconnection facility must cause the generator to cease to energize the Wires Owner's system within the trip times indicated in the following table. ("Trip time" is the period of time between the start of the abnormal condition and the moment the interconnection device ceases to energize the Wires Owner's system.)

Response to Abnormal Voltages	
RMS Voltage	Trip Time
RMS Voltage: $V \leq 60$ ($V \leq 50\%$)	Trip time: Instantaneous
RMS Voltage: $60 < V < 108$ ($50\% < V < 90\%$)	Trip time: 120 cycles
RMS Voltage: $108 \leq V \leq 127$ ($90\% < V < 106\%$)	Normal Operation
RMS Voltage: $127 < V < 144$ ($106\% < V < 120\%$)	Trip time: 30 cycles
RMS Voltage: $V \geq 144$ ($V \geq 120\%$)	Trip time: Instantaneous

The DG Owner may reconnect when the distribution system is stabilized (i.e., voltage and frequency have returned to normal range for at least five minutes).

3.3.9 Over-Frequency and Under-Frequency Protection

The DG Owner must install frequency selective relays to separate the generation facility from the Wires Owner's system in cases of extreme variations in frequency.

Under-frequency and over-frequency relaying that automatically disconnects generators from the distribution system must be time delayed, in accordance with the Transmission Administrator's requirements as per section 3.2.4. The DG Owner may reconnect when the distribution system is stabilized.

3.3.10 Anti-Islanding

The DG Owner's generation facility must be equipped with protective hardware and software designed to prevent the generator from being connected to a de-energized circuit owned by the Wires Owner.

At the discretion of the Wires Owner, the DG Owner may install under-frequency tripping and over-frequency tripping for anti-islanding that will not negatively impact WSCC criteria, in conjunction with their load shedding schemes.

In most cases, the generation facility will routinely operate as a part of the interconnected system. A problem on the system could lead to the generator becoming islanded (i.e., the generator becomes the sole supplier of power to one or more of the Wires Owner's customers). The resulting irregularities in power quality could cause damage for other customers.

To prevent this possibility, the DG Owner must use teleprotection signals from the distribution system or another reliable means to separate the generator from the distribution system in the event of islanding. If other means are used to detect islanding, the scheme must consist of reliable primary and backup functions using different quantities.

The DG Owner is responsible for damage caused as a result of failure to safely separate during an islanding event.

Where there could be a reasonable match between the DG Owner's generation and the islanded load, conventional methods may not be effective in detecting the islanded operation. In this case, the Wires Owner will require the addition of transfer trip communication facilities to remotely trip-off the DG Owner's generation upon opening the distribution feeder main circuit breaker or circuit recloser.

3.3.11 Telemetry

Where a generator could adversely affect the distribution system (e.g., by providing inflow into a fault) the DG Owner must have systems in place to inform the Wires Owner of the protective operations that occurred or failed to occur.

The WSCC's Compliance Monitoring and Operating Practices Subcommittee requires Wires Owners, Transmission System Owners and the System Controller to provide telemetry of MW, MVAR, and breaker-status of all significant generation. "Significant" is presently defined as a capacity of 5MW or greater, although in some sensitive areas, the Wires Owner may require telemetry or transfer trip for smaller generators. See Table 2.

3.3.12 Requirements for Transfer Trip

Where transfer trip protection is required, the transfer trip protection must ensure that the generator does not “island” in the event of substation breaker or intermediate OCR operation. General requirements are:

- Generator lockout within 0.6 seconds of breaker or OCR operation; and
- Fail-safe lockout within 6 seconds of communication loss.

The DG Owner is responsible for detecting and tripping in the event of a communication loss.

Transfer tripping requirements are also applicable to induction generators, unless the DG Owner can demonstrate that there is no potential for self-excitation.

3.3.13 Special Interconnection Protection

In some cases, provision for generator-specific protection and controls will be necessary, such as out-of-step or loss of synchronism.

Additionally, the DG Owner needs to be aware that unbalance conditions can occur in the distribution system, especially under system fault conditions, and the design of the interconnection facility should take this into account.

For Star-Delta interconnection transformers, the unbalance fault current could damage the generator interconnection transformer under certain fault conditions. This is a result of the circulating current, which occurs in the Delta winding of the interconnection transformer in an attempt to balance the fault current. Protection for the transformer may be required to address this issue.

3.3.14 Flicker

The DG Owner must not cause excessive voltage flicker on the distribution system. The flicker must not exceed the Wires Owner’s flicker guidelines.

3.3.15 Harmonics

In accordance with IEEE 519, the total harmonic distortion (THD) voltage must not exceed five per cent of the fundamental 60 Hz frequency, nor three per cent of the fundamental for any individual harmonic, when measured on the Wires Owner’s side at the PCC.

3.3.16 Inadvertent Energization of Wires Owner's Facilities

The DG Owner's generator must not energize the Wires Owner's facilities when the Wires Owner's facilities are de-energized.

3.3.17 Protection from Electromagnetic Interference

The influence of electromagnetic interference (EMI) must not result in a change in state or misoperation of the interconnection facility.

3.3.18 Surge Withstand Performance

The interconnection facility must have the capability to withstand voltage and current surges in accordance with the environments described in IEEE/ANSI C62.41 or C37.90.1.

3.3.19 Synchronization

Connection must be prevented when the DG Owner's synchronous generator and/or power system is operating outside of the following limits:

Aggregate Ratings of Generation (kVA)	Frequency Difference (Hz)	Voltage Difference (%)	Phase Angle Difference (degrees)
0-500	0.3	10	20
>500 – 1500	0.2	5	15
>1500	0.1	3	10

3.4 Typical Interconnection Requirements

While the typical interconnection requirements for safely operating the DG Owner's generation facility in parallel with the Wires Owner's distribution system are specified below, specific interconnection locations and conditions may require more restrictive protective settings or hardware, especially when exporting power to the Wires Owner's system. The Wires Owner must make these deviations known to the DG Owner as soon as possible. An example of one such restrictive area for DG interconnection is with utility secondary network systems. The DG Owner will need to work closely with the Wires Owner to determine whether interconnection and operation within a specific network system is possible.

Part 2: Guide for Generator Interconnection

Protective relays, electric conversion devices and other devices can comply with this Guide by demonstrating the required protective function, as specified in Tables 1, 2 and 3.

3.4.1 Single-Phase Generators

Table 1 shows the protective function requirements for single-phase generators. Inverter-type generators must meet the criteria established in IEEE 929 Recommended Practice for Utility Interface of Photovoltaic (PV) Systems, and be certified to UL 1741 and CSA 22.2 #107.1.

3.4.2 Three-Phase Synchronous Generators

Table 2 shows the protective function requirements for three-phase synchronous generators of various sizes.

The DG Owner's generator circuit breakers must be three-phase devices with electronic or electromechanical control.

The DG Owner is solely responsible for properly synchronizing its generator with the Wires Owner's system.

The DG Owner is also responsible for ensuring that the interconnection protection device settings coordinate with the Wires Owner's protective device settings.

3.4.3 Three Phase induction Generators and Three-Phase Inverter Generators

Table 2 shows the protective function requirements for three-phase induction and inverter generators of various sizes.

Induction generators may be connected and brought up to synchronous speed (as an induction motor) if it can be demonstrated that the initial voltage drop measured on the Wires Owner's side at the PCC is within the flicker limits. Otherwise, the DG Owner may be required to install hardware or utilize other techniques to bring voltage fluctuations to acceptable levels.

Inverter generators must meet the applicable criteria in IEEE 929 and be certified to UL 1741 and CSA 22.2 #107.1.

Line-commutated inverters do not require synchronizing equipment. Self-commutated inverters, whether of the utility-interactive type or stand-alone type, must be used in parallel with the Wires Owner's system only with synchronizing equipment. Direct Current (DC) generation must not be directly paralleled with the Wires Owner's system.

3.4.4 Generators Paralleling for Six Cycles or Less (Closed Transition Switching)

Table 3 shows the protective function requirements for generators 10 MW or less which parallel with the Wires Owner's system for six cycles or less.

Generators meeting this description must apply for **Parallel Operation**, sign a Joint Operating Agreement, sign an Operating Schedule and meet all other requirements of this Guide.

3.4.5 Mitigation of Protection Scheme Failure

Relays with self-diagnostic features provide information on the integrity of the protection scheme and should be used whenever possible.

The protection scheme must be designed by a qualified engineer or a competent technical person, working with the Wires Owner's engineers, to ensure that the self-diagnostic feature is integrated into the overall protection scheme for the safe and reliable operation of the distribution system.

Depending on the scheme and its design, where relays with the self-diagnostic feature do not trip the appropriate breaker(s), sufficient redundant or backup protection must be provided for the distribution system. The malfunctioning relay must also send a signal to notify operating personnel to investigate the malfunction.

Older electro-mechanical relays are generally not equipped with self-diagnostic features. Design of protection and control schemes must therefore be of a fail-safe nature to maintain the integrity of the protection in the event there is a malfunction.

3.4.6 Maximum Generator Power to be Exported

Where the DG Owner's generation capacity exceeds the load-carrying capacity of the generator interconnection at the PCC, or exceeds the capacity of the Wire Owner's system connected to the generator, the DG Owner must install protection to limit the amount of export power to the rated capacity of the Wires Owner's system or to the contracted export amount, whichever is less.

3.4.7 Interconnection Protection Approval

The DG Owner must provide the Wires Owner with complete documentation of the proposed interconnection protection scheme for review against the requirements of this Guide, and for potential impacts to the Wires Owner's system.

The documentation should include:

- A completed application form;
- An overall description of how the protection will function;
- A detailed Single Line Diagram;
- Identification details of the protection components (i.e., manufacturer, model, etc.);
- The protection component settings (i.e., trigger levels and time values); and
- Identification details of the disconnect switch (i.e. manufacturer, model and associated certification).

The DG Owner must revise and re-submit the protection information for any proposed modification.

4.0 Construction

4.1 General

The DG Owner's generation facility must be constructed and installed to meet all applicable regulations. All permitting and safety code requirements must be completed and copies of inspection reports provided to the Wires Owner prior to energizing the PCC.

All Single Line Diagrams provided to the Wires Owner must be drawn in accordance with IEEE standards and conventions, and stamped by a licensed, professional engineer assuming responsibility for the design.

5.0 Metering

5.1 General

Metering must comply with Measure Canada requirements and the latest revisions of the TA (Transmission Administrator of Alberta Ltd.) Measurement System Standard, where applicable, and be approved by the Wires Owner.

The primary side (i.e., the side connected to the Wires Owner's distribution system) of the interconnection transformer is the Measuring Billing Point for distributed generation export conditions, and the low side (i.e., the side connected to the DG Owner's generation facility) of the interconnection transformer is the Measuring Billing Point for distributed generation import conditions. In all cases where the metering equipment is installed on the low side of the interconnecting transformer, transformer loss compensation must be installed in the meter for generation export conditions.

The metering equipment must be:

- Suitable for use in the environmental conditions reasonably expected to occur at the installation site over the course of a typical year; and
- Appropriate for the power system characteristics reasonably expected to exist at the installation site under all power system conditions and events.

5.2 Meter Requirements

An interval meter must be installed at all distributed generation sites, with exceptions as outlined in the Settlement System Code of Alberta.

The meter must:

- Be Measurement Canada approved under Section 9(1), Section 9(2) or Section 9(3) of the Electricity and Gas Inspection Act;
- Be verified and sealed in accordance with the Electricity and Gas Inspections Act, subject to the terms and conditions of any applicable dispensation(s);
- Be capable of maintaining the interval boundaries within 60 seconds of the hour and every quarter hour thereafter.
- Measure all quantities required to determine active energy and reactive energy transferred in the required directions at the Measuring Billing Point;
- Provide a separate register to maintain the continuously cumulative readings of the active energy and reactive energy transferred in the required directions at the Measuring Billing Point;
- Retain readings and, if applicable, all clock functions for at least 14 days in the absence of line power;
- Have an accuracy class rating for active energy measurement that equals or exceeds the values specified in Appendix I, Schedule 1, for non-dispensated metering equipment and Schedule 2 for dispensated metering equipment;

Part 2:

Guide for Generator Interconnection

- Have an accuracy class rating for reactive energy measurement that equals or exceeds the values specified in Appendix I, Schedule 1 for non-dispensated metering equipment and Schedule 2 for dispensated metering equipment; and
- Have “LOSS COMPENSATED” clearly indicated, if the meter is internally compensated for line or transformer losses.

5.3 Measurement Transformers

The applicable winding(s) of the current and potential instrument transformers must:

- Be Measurement Canada approved under Section 9(1), Section 9(2) or Section 9(3) of the Electricity and Gas Inspection Act;
- Be burdened to a degree that does not compromise the accuracy required by this Guide; and
- Have an accuracy class rating that equals or exceeds the values specified in Appendix I, Schedule 1 for non-dispensated metering equipment.

5.4 Remote Communications Equipment

Remote communications equipment may or may not be an integral part of the meter or the recorder, but must incorporate protocol schemes suitable for the type/nature of the communications media/path that will prevent data corruption during interval data transmission.

5.5 Password Protection

Two or more levels of password protection are required for each meter data collection agency: one for full access to set time functions; and one for read-only access to interval data, the event log and meteorological quantities.

5.6 Safety Requirements

The installation must conform to:

- Measurement Canada Standard Drawings;
- CSA Standard C22.2; and
- ANSI/IEEE C57.13-1983 IEEE Guide for Grounding of Instrument Transformer Secondary Circuits and Cases.

6.0 Inspection

The DG Owner must maintain a quality control and inspection program satisfactory to and approved by the Wires Owner.

In addition to the DG Owner's normal inspection procedures, the Wires Owner reserves the right to witness the manufacturing or fabrication of, or any work involving, the subject equipment; to inspect materials, documents, manufacturing operations and installation procedures; to witness tests and to evaluate the results of non-destructive examinations.

The DG Owner must supply the Wires Owner with a complete set of detailed drawings to assist the Wires Owner in its inspection of equipment during testing.

7.0 Testing

7.1 General

The DG Owner must notify the Wires Owner in writing at least two weeks prior to the initial energization and start-up testing of the DG Owner's generation facility, and the Wires Owner may witness the testing of any equipment and protective systems associated with the interconnection. The tests and testing procedures must generally align with the requirements specified in IEEE P1547.

This section is divided into **type testing** and **verification testing**:

- **Type testing** is performed or witnessed once by an independent testing laboratory for a specific protection package. Once a package meets the type testing criteria described in this section, the design is accepted by the Wires Owner. If any changes are made to the hardware, software, firmware or verification test procedures, the manufacturer must notify the independent testing laboratory to determine what, if any, parts of the type testing must be repeated. Failure of the manufacturer to notify the independent testing laboratory of any changes may result in withdrawal of approval and disconnection of units installed after the change was made.
- **Verification testing** is site-specific, periodic testing to assure continued acceptable performance.

These testing procedures apply only to devices and packages associated with protection of the interconnection between the generation facility and the Wires Owner's system. Interconnection protection is usually limited to voltage relays, frequency relays, synchronizing relays, reverse current or power relays and anti-islanding schemes. Testing of relays or devices associated specifically with protection or control of generating equipment is recommended, but not required unless the devices impact the interconnection protection.

Protection testing must include procedures to functionally test all protective components of the protection scheme, up to and including tripping of the generator and/or PCC. The testing must verify all protective set points and relay/breaker trip timing.

At the time of production, all interconnecting equipment and discrete relays must meet or exceed the requirements of ANSI /IEEE C62.41-1991 Recommended Practices on Surge Voltages in Low Voltage AC Power Circuits or C37.90.1 1989 IEEE Standard Surge Withstand Capability (SWC) Tests for Protective Relays and Relay Systems. If C62.41-1991 is used, the surge types and parameters must be applied to the equipment's intended insulation location, as applicable.

The manufacturer's verification test and the appropriate dielectric test specified in UL 1741 must also be performed.

7.2 Type Testing

All interconnection equipment must include a type testing procedure as part of the documentation. The type testing must determine if the protection settings meet the requirements of this Guide.

Prior to type testing, all batteries must be disconnected or removed for a minimum of 10 minutes. This test will verify the system has a non-volatile memory and that the protection settings are not lost. A test must also be performed to determine that the failure of any battery used to supply trip power will result in an automatic shutdown.

All inverters must be non-islanding, as defined by IEEE 929. Inverters must, at the time of production, meet or exceed the requirements of IEEE 929 and UL 1741.

7.3 Verification Testing

Prior to parallel operation of a generation facility, or whenever the interconnection hardware or software is changed, verification testing must be performed. The verification test must be performed by a qualified individual in accordance with the manufacturer's published test procedure. Qualified individuals include: licensed, professional engineers; factory-trained and certified technicians and licensed electricians experienced in testing protective equipment. The Wires Owner reserves the right to witness the verification test or to require written certification that the test was performed.

Verification testing must be performed annually. All verification tests prescribed by the manufacturer or developed by the DG Owner and agreed to by the Wires Owner must be performed. The DG Owner is responsible to maintain the verification test reports for inspection by the Wires Owner.

Inverter generator operation must be verified annually, by operating the load break disconnect switch and verifying that the generation facility automatically shuts down and does not restart for five minutes after the switch is closed.

Any system that depends on a battery for trip power must be checked for proper voltage and logged monthly. Once every four years, the battery must either be replaced or a discharge test performed.

7.4 Protective Function Testing

Protection settings that have been changed after factory testing must be field verified to show that the device trips at the measured (actual) voltage and frequency. Tests must be performed using secondary injection, applied waveforms or a simulated utility. Alternatively, if none of the preceding tests can reasonably be done, a settings adjustment test can be performed if the unit provides discrete readouts of the settings.

The non-islanding function, if available, must be checked by operating a load break switch to verify that the interconnection facility ceases to energize its output terminals and does not restart for the required time delay after the switch is closed.

A reverse power or minimum power function, if used to meet the interconnection requirements, must be tested using secondary injection techniques. Alternatively, this function can be tested by means of a local load trip test or by adjusting the DG output and local loads to verify that the applicable non-export criterion (i.e., reverse power or minimum power) is met.

7.5 Verification of Final Protective Settings Test

If protective function settings have been adjusted as part of the commissioning process, then, at the completion of the adjustment, the DG Operating Authority must confirm all devices are set to the Wires Owner's approved settings.

Interconnection protective devices that have not previously been tested as part of the interconnection facility with their associated instrument transformers, or that are wired in the field, must be given an in-service test during commissioning. This test is to verify proper wiring, polarity, sensing signals, CT/PT ratios and operation of the measuring circuits.

For protective devices with built-in metering functions that report current and voltage magnitudes and phase angles or magnitudes of current, voltage, and real and reactive power, the metered values can be compared to the expected values. Alternatively, calibrated portable ammeters, voltmeters and phase-angle meters may be used.

7.6 Hardware and Software Changes

Whenever changes are made to interconnection hardware or software that can affect the functions listed below, the potentially affected functions must be retested:

- Over-voltage and under-voltage.
- Over-frequency and under-frequency.
- Non-islanding function (if applicable).
- Reverse or minimum power function (if applicable).
- Inability to energize dead line.
- Time delay restart after Wires Owner outage.
- Fault detection, if used.
- Synchronizing controls (if applicable).

To ensure that commissioning tests are performed correctly, the Wires Owner may wish to witness the tests and receive written certification of the results.

Refer to Appendix H for an example of a protective settings commissioning document.

7.7 Switchgear and Metering

The Wires Owner reserves the right to witness the testing of installed switchgear and metering.

The DG Owner must notify the Wires Owner at least 10 days in advance of any testing.

Part 2: Guide for Generator Interconnection

8.0 Data Requirements

The following table identifies the drawings and data the DG Owner is required to submit to the Wires Owner when applying for interconnection to the Wire's Owner's system.

Drawing/Data	Proposal	Approval*	Verified
Manufacturer's equipment data sheet			X
Control schematic		X	X
Single Line Diagram indicating proposed protection settings	X	X	X
Description of protection scheme	X	X	X
Generator nameplate schedule		X	X
Fuse and protective relay coordination study & settings		X	X
Current transformer characteristic curve		X	X
Commissioning report c/w protection settings			X
Plot plan showing location of lockable, visible disconnect switch	X	X	X

*The minimum time requirement for reviewing this information is generally 10 working days.

9.0 Marking And Tagging

The nameplate on the switchgear must include:

- the manufacturer's name; and
- the manufacturer's serial number.

In addition, the disconnect switch must be clearly marked "DG Disconnect Switch" and tagged with an identification number approved by the Wires Owner.

10.0 Maintenance

All of the equipment, from the generator up to and including the PCC, is the responsibility of the DG Owner.

The DG Owner must maintain the equipment to accepted industry standards, in particular the Part 1, paragraph 2-300 of the CEC. Failure to do so may result in disconnection of the generator.

The DG Owner must present the planned maintenance procedures and a maintenance schedule for the interconnection protection equipment to the Wires Owner, and keep records of such maintenance.

Maintenance procedures for the Wires Owner's system up to the PCC must be in compliance with the Wires Owner's published "Guidelines for Connecting Generators to the Wires Owner's Distribution System."

Part 2: Guide for Generator Interconnection

Table 1:

Interconnection Protective Function Requirements¹ Single-Phase Connected to Secondary or Primary System

Generator Size	50 kW or less
Interconnect Disconnect Device	X
Generator Disconnect Device	X
Over-Voltage Trip	X
Under-Voltage Trip	X
Over/Under Frequency Trip	X
Overcurrent	X
Synchronizing Check ²	Manual or Automatic
Anti-islanding protection	

Notes:

1. X means required.
2. For synchronous and other types of generators with stand-alone capability.
3. Exporting to the Wires Owner's system may require additional operational/protection devices, and will require coordination of operations with the Wires Owner.
4. Switchgear standards for 50 kW or less and less than 750 volts will be relaxed to fixed-type breakers.

Part 2: Guide for Generator Interconnection

Table 2:

Interconnection Protective Function Requirements⁵ Three-Phase Connected to Secondary or Primary System

Generator size classifications:		SMALL			MEDIUM		LARGE
		10 kW or less	10 kW - 200 kW	200 kW - 500 kW	500 - 2,000 kW	2,000 - 12,500 kW	12 500 - 50 000 kW
Device #							
	Interconnect Disconnect Device	X	X	X	X	X	X
	Generator Disconnect Device	X	X	X	X	X	X
25	Synchronous Check(note 1)	Y Man. or Auto.	Y Man. or Auto.	Y Man. or Auto.	Y Automatic	Y Automatic	Y Automatic
	Otv:	(1)	(1)	(1)	(1)	(1)	(1)
27	Under-Voltage Trip	Y	Y	Y	Y	Y	Y
	Otv:	(3)	(3)	(3)	(3)	(3)	(3)
32	Power Direction/Reverse Power	Y(note 2)	Y(note 2)	Y(note 2)	X(note 3)	X(note 3)	
	Otv:	(1)	(1)	(1)	(1)	(1)	
46	Negative Phase Sequence Overcurrent (Phase unbalance, reverse phase sequence)			X	X (1)	X (1)	X (1)
51V	Overcurrent, voltage restrained (Optional, to prevent nuisance trips)	X	X	X	X	X	X
	Otv:	(1)	(1)	(1)	(3)	(3)	(3)
50/51	Inst/Timed Overcurrent	X	X	X	X	X	X
	Otv:	(3)	(3)	(3)	(3)	(3)	(3)
50N	Instantaneous Neutral Overcurrent			X	X	X	X
	Qty:			(1)	(1)	(1)	(1)
	Ground Over Voltage Trip(note 6) or			X	X	X	X
51G	Ground Over Current Trip(note 6)	Otv:		(1)	(1)	(1)	(1)
TT	Transfer Trip(note 4) (Based on impact to IPP and utility)	Y(note 4)	Y(note 4)	Y(note 4)	Y(note 4)	Y(note 4)	Y(note 4)
	Telemetry data communication			Y(note 4)	Y(note 4)	Y(note 4)	Y(note 4)
	Automatic Voltage Regulation (AVR) ¹					X	X
	Qty:					(1)	(1)
59I	Instantaneous Over-Voltage Trip (For ferroresonance conditions)	Y	Y	Y	Y	Y	Y
	Otv:	(3)	(3)	(3)	(3)	(3)	(3)
59T	Over-Voltage Trip	Y	Y	Y	Y	Y	Y
	Otv:	(3)	(3)	(3)	(3)	(3)	(3)
60	Voltage Balance Relay						X (1)
67/67N	Directional Overcurrent	Y(note 2)	Y(note 2)	Y(note 2)	Y(note 2)	Y(note 2)	Y(note 2)
	Otv:	(3)/(1)	(3)/(1)	(3)/(1)	(3)/(1)	(3)/(1)	(3)/(1)
81/O, 81/L	Over/Under Frequency Trip	Y	Y	Y	Y	Y	Y
	Otv:	(3)	(3)	(3)	(3)	(3)	(3)
	Anti-islanding for inverters IEEE 929 and UL 1741	Y	Y	Y	Y	Y	Y

Part 2: Guide for Generator Interconnection

Table 2 (Continued):

Interconnection Protective Function Requirements⁵ Three-Phase Connected to Secondary or Primary System

Notes:

1. For synchronous and other types of generators with stand-alone capability.
2. Only required on synchronous generators that are for on-site load only. If NOT exporting and generator is less than minimum load of DG Owner or if always exporting, then relay not required except as noted.
3. If exporting, frequency blocks under trip with agreement of Wires Owner.
4. Transfer trip with fail-safe design required for synchronous machines.
5. Exporting to the Wires Owner may require additional operational/protection devices and coordination of operations with the Wires Owner.
6. Selection depends on grounding system, if required by Wires Owner.
7. Quantity shown in brackets below (e.g., (3)).
8. Both X and Y are required by this guideline X is IEEE Std 242 Protection Requirement.
9. Three-directional overcurrent relays may be substituted for reverse power relay.
10. Above to be in accordance with the Canadian Electrical Code.

Part 2: Guide for Generator Interconnection

Table 3:

Interconnection Protective Function Requirements Generators Connected to Secondary or Primary System

For 6 cycles or less (Closed Transition Switching)

Generator Size	10 MW or less
Interconnect Disconnect Device	X
Generator Disconnect Device	X
Over-Voltage Trip	X
Under-Voltage Trip	X
Over/Under Frequency Trip	X
Overcurrent	X
Ground Over-Voltage Trip ¹ Or Ground Over-Current Trip ¹	X
Synchronizing Check ²	Manual or Automatic

Notes:

1. Selection depends on grounding system, if required by the Wires Owner.
2. For synchronous and other types of generators with stand-alone capability.

Alberta Distributed Generation Interconnection Guide

Appendices

In this part...

- Appendix A: Approval Process Block Diagram
- Appendix B: Information Required From DG Owner
- Appendix C: Information Provided by Wires Owner
- Appendix D: Joint Operating Agreement
- Appendix E: Applicable Codes and Standards
- Appendix F: Single Line Diagram For Wye-DeltaInterconnection
- Appendix G: Single Line Diagram For Wye-Wye Interconnection
- Appendix H: Protective Settings Commissioning Document
- Appendix I: Accuracy Schedules for Metering Equipment

Appendices

Appendix A: Approval Process Block Diagram

Note: Process assumes DG Owner has internal project approval

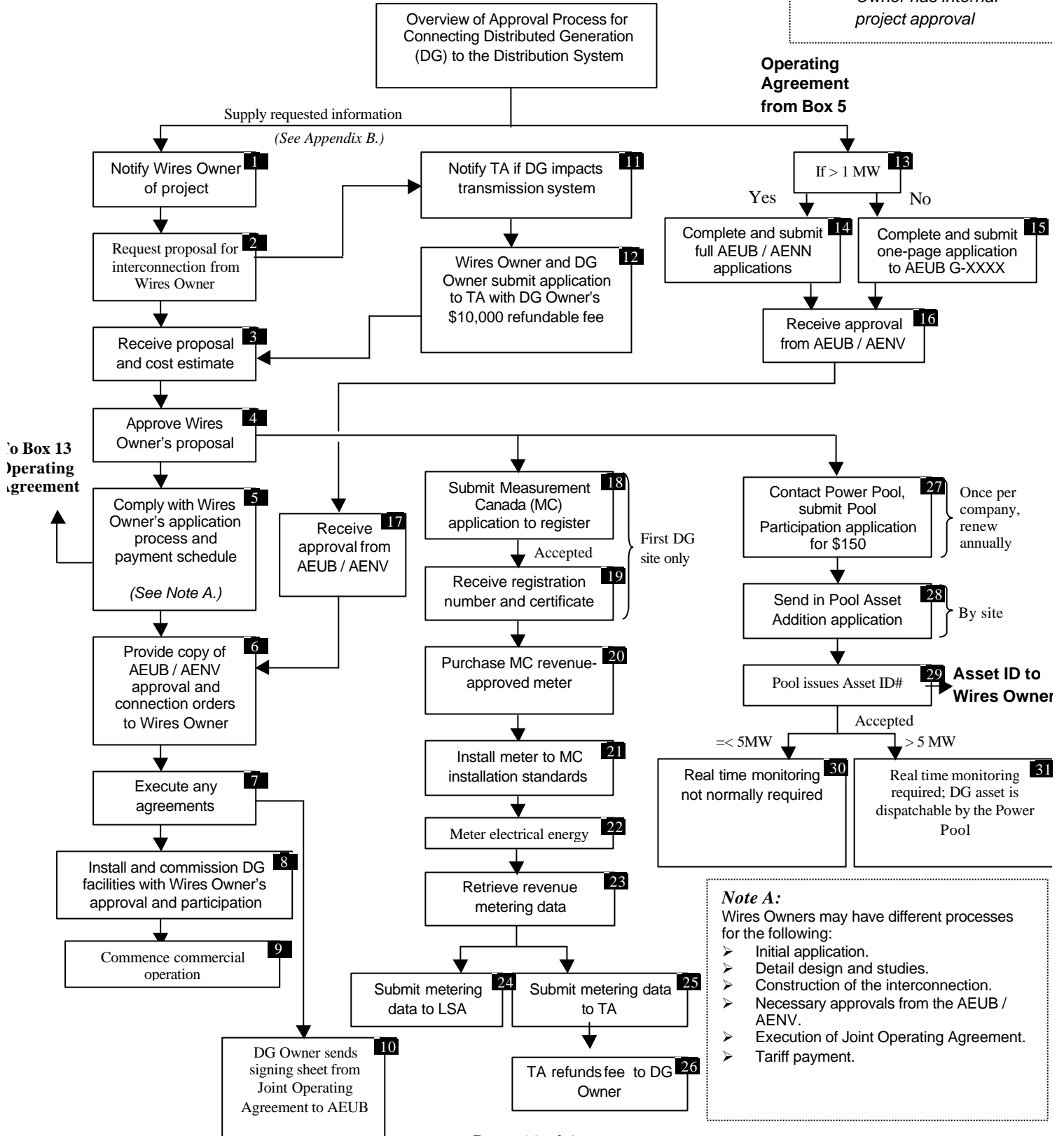

Note A:
Wires Owners may have different processes for the following:

- Initial application.
- Detail design and studies.
- Construction of the interconnection.
- Necessary approvals from the AEUB / AENV.
- Execution of Joint Operating Agreement.
- Tariff payment.

Notes on the Approval Process

Power Pool

To sell electric energy through the Power Pool of Alberta, a DG Owner must become a Pool Participant. This involves signing a Participant contract, paying trading charges and signing an agreement with the Transmission Administrator. Importers and exporters must also demonstrate that they have service agreements for transmission between Alberta and the adjoining province, state or territory.

Joint Operating Agreement

A generic Joint Operating Agreement is provided in Appendix C. The DG Owner must contact the Wires Owner to negotiate a Joint Operating Agreement for the specific interconnection.

AEUB Approval

For AEUB procedures, access the AEUB website at www.eub.ab.ca.

Appendix B: Information Required From DG Owner

The DG Owner must submit detailed information for the Wires Owner to design, construct, operate and maintain their portion of the interconnection. The required information may include the following:

Information Requirements	Required at Application	Required During Design
1) DG OWNER'S CONTACT NAMES AND ADDRESSES		
a) Company name _____	X	
b) Contact for commercial terms : Name/Title _____ Address _____ Phone/Fax _____	X	
c) Contact for engineering design : Name/Title _____ Address _____ Phone/Fax _____	X	
d) Contact for operating terms : Name/Title _____ Address _____ Phone/Fax _____	X	
2) GENERAL INFORMATION		
a) Detailed map showing the proposed plan location <input type="checkbox"/> Attached		X
b) Site plan showing the arrangement of major equipment <input type="checkbox"/> Attached		X

Appendices

- c) Diagram showing the voltage and current rating of each component X
 Attached

3) OPERATING CHARACTERISTICS

- a) Indicate how the facility will operate. X
 The facility is intended to sell electric energy to the Power Pool.
 The facility will consume electric energy services from the electric system.

4) GENERATOR

- a) Type X
 Synchronous Induction Inverter
- b) Manufacturer _____ Model _____ X
- c) Nominal rating X
 _____ kW
 _____ kVA
 _____ Volts
- d) Single-Phase Three-Phase X
- e) Governor droop _____ % X
- f) Generator connection configuration X
 Delta Wye
- g) Generator grounding X
- h) Impedances (positive, negative and zero sequence) X
 Direct axis transient _____
 Direct axis subtransient _____
 Quadrature axis transient _____
 Quadrature axis subtransient _____

5) PRIME MOVER

- a) Type _____ X
- b) Manufacturer _____ X
- c) Model _____ X

Appendices

- d) Rating _____ X
e) Inertia constant _____ X
- 6) POWER FACTOR REGULATOR**
- a) Limits of range of reactive power X
Lagging (out) _____ VAr
Leading (in) _____ VAr
b) Accuracy tolerance of setting _____ X
- 7) VOLTAGE REGULATOR**
- a) Voltage regulator setting range _____ to _____ Volts X
b) Voltage regulator setting tolerance _____ % X
- 8) COMPENSATOR (IF APPLICABLE)**
- a) Type of input(s) _____ X
b) Compensating resistance(s) _____ reactance(s) _____ X
- 9) DG OWNER – SUPPLIED TRANSFORMERS**
- a) Rating X
Base _____ KVA
Fan rating _____
Cooling type _____
- b) High Voltage Winding X
_____ V nominal voltage
_____ Connection
 Grounded Ungrounded N/A
- c) Low Voltage Winding X
_____ V nominal voltage
_____ Connection
 Grounded Ungrounded N/A

Appendices

- d) Tertiary voltage winding (if applicable) X
_____ V nominal voltage
_____ Connection
 Grounded Ungrounded N/A
- e) Impedances X
H-X % _____ % base _____ kVA
H-Y % _____ % base _____ kVA
X-Y % _____ % base _____ kVA
- f) Tap changer X
 Onload Offload None
 Tap chart attached
- g) Instrument transformers (if applicable) X
Multi-ratio Yes (List Ratios Available) No
Proposed ratio _____
Accuracy class _____

10) INTERCONNECTION PROTECTION

- a) Complete and accurate protection diagrams X
 Attached
- b) Description of the proposed protection schemes X
 Attached
- c) Diagrams X
 Single line
 Schematic
 Wiring
- d) Interconnection X
 Verify interconnection functionality
 Site test and settings
- e) Maintenance plans for the: X
 Interconnection protection devices
 Interconnection interrupting devices

Appendices

11) **COMPLIANCE WITH SAFETY CODES ACT**

Permit or equivalent X

12) **METERING**

2 Element 3 Element X

Meter service provider _____ X

Meter data manager _____ X

Asset ID # _____ X

Modeling Information

In some cases, a generator (or the aggregate generation on a line) is large enough that adjacent customers or the dynamic stability of the Wires Owner's distribution system could be affected. The DG Owner is responsible for the cost of any required transient or dynamic stability studies, and the studies must be done in a manner suitable to, and approved by, the Wires Owner.

DG Owners are responsible for ensuring the data they submit provides an adequate mathematical representation of the facility's electric behavior. If the data is not available prior to purchasing equipment, it must be submitted as soon as it becomes available.

The studies must accurately determine:

1. The impact of the DG Owner's facility on adjacent customers of the Wires Owner.
2. The dynamic stability, in aggregate, of the Wires Owner's system as an interconnected system within the WSCC.

Data may be supplied by the manufacturer or acquired directly by testing. It must include generator characteristics (i.e., speed, reactance, resistance, excitation system etc.) and governor characteristics (i.e., lead time/lag time constants, valve or gate opening data etc.).

The information requirements vary for induction generators and inverter generators, and for hydro or steam systems.

Appendix C: Joint Operating Agreement

This template is generic. Each Wires Owner will use their own specific format.

INTERCONNECTION and OPERATING AGREEMENT

between

_____ (the DG Owner)

and

_____ (the Wires Owner)

This Agreement provides for the safe and orderly operation of the electrical facilities interconnecting the DG Owner's generation facility at **(land location or description of project)** and the electrical distribution system owned by the Wires Owner.

This Agreement does not supersede any requirements outlined in Government Regulations such as (but not limited to) the Alberta Electric and Communication Utility Code, the Canadian Electrical Code and the Occupational Health and Safety Act; nor does it supersede any terms of the Commercial Contract between the DG Owner and the Wires Owner.

1. **Intent of Parties:** It is the intent of **(the DG Owner)** to generate for sale to the Power Pool of Alberta up to the maximum available power, and to dispatch the amount of power produced at their discretion.

It is the intent of the Wires Owner to operate the distribution system to maintain a high level of service to their customers and to maintain a high level of power quality.

It is the intent of both parties to operate the facilities in a way that ensures the safety of the public and their employees.

2. **Operating Authority:** The Operating Authority is the person identified by name or job title responsible to establish operating procedures and standards within their organization. The Operating Authority shall ensure that timely updates are made to this document to reflect any changes to system operating characteristics, disconnect devices and Single Line Diagrams referenced in this document. The Operating Authorities for the DG Owner and for the Wires Owner shall ensure that the operators of the generation facility and the distribution system are competent in the operation of the electrical systems and are aware of the provisions of any operating agreements and regulations relating to the safe operation of electrical power systems.

The Operating Authority for **(the DG Owner)** is **(name or title of person designated the Operating Authority, their address and phone numbers)**.

The Operating Authority for the Wires Owner is **(name or title of person designated the Operating Authority, their address and phone numbers)**.

3. **Operator in Charge:** The Operator in Charge is the person identified by name or job title responsible for the real time operation of all electrical facilities related to the interconnection and owned by their organization.

The Operator in Charge for **(the DG Owner)** is **(name or title of person designated the Operator in Charge, their address and phone numbers)**.

The Operator in Charge for the Wires Owner is **(name or title of person designated the Operator in Charge, their address and phone numbers)**.

4. **Description:** **(The DG Owner's)** facilities consist of a **(size), (type), (connection)** generator connected to the distribution system through the main bus at the facility. **(The DG Owner)** owns and is responsible for the maintenance and operation of all facilities on the generator side of **(the Point of Common Coupling)**.

The Wires Owner's distribution system consists of 25 kV line **(line number)** and a **(transformer size), (transformer connection designation)** transformer. The Wires Owner owns and is responsible for the operation of all facilities on the distribution side of **(the Point of Common Coupling)**.

The Point of Common Coupling is designated as **(description of Point of Common Coupling)**, and is identified on the attached Single Line Diagram.

The **(breaker, switch etc.) (switch number)** will be used as the main disconnect point for the facility, and is owned and operated by **(the DG Owner or the Wires Owner)**. This switch **(does/does not)** have load-break capability and therefore **(can/cannot)** be operated while the generation facility is producing or consuming power.

The generation facility is designed to operate connected to the grid, with synchronizing facilities provided on the DG Owner's breaker **(breaker number)**. In the absence of outstanding clearances between the Operators in Charge, notice is not required to be given to the Wires Owner prior to synchronization taking place. It is recognized by **(the DG Owner)** that there are no synchronization schemes in place on the Wires Owner's system, and that the **(upstream distribution facility)** contains automatic equipment that will provide for voltage regulation or automatic reclosure under some conditions. **(Insert description of any special blocking or protection schemes.)**

The generator is capable of controlling either voltage or power factor, and is normally set to control **(voltage or power factor)** to **(setting, tolerance)** at the generator terminals. **(Islanded capabilities to be identified here also, if any)**.

5. **Suspension of Interconnection:** It is intended that the interconnection will not compromise the Wires Owner's protection or operational requirements. The operation of the **(DG Owner's)** facilities and the quality of electric energy supplied by **(the DG Owner)** shall meet the standards specified in Part 2 of the Alberta Distributed Generation Interconnection Guide and any further standards identified by the Wires Owner. If the operation of the **(DG Owner's)** facilities or quality of electric energy supplied does not meet the standards as specified, then the Wires Owner will notify **(the DG Owner)** to take reasonable and expedient corrective action. The Wires Owner shall have the right to disconnect the **(DG Owner's)** facilities until compliance is reasonably demonstrated. Notwithstanding, the Wires Owner may, in its sole discretion, disconnect the **(DG Owner's)** generation facility from the distribution system without notice if the operation of the generation facility may be or may become dangerous to life and property.

Appendices

6. **Safe Work Planning:** Safe work planning practices such as pre-job plans and tailboard conference procedures shall be followed whenever both parties are involved in work on the interconnected system. Nothing in this document should be interpreted as altering the intent of the Wires Owner's safe practices manual or safe operating procedures. Any contradictions are to be identified and resolved prior to work commencing.

Safe work routines described in Division D of the Electrical and Communication Utility Systems Regulations (AECUC) shall be followed when providing isolation for work on any part of the interconnected system.

7. **Maintenance Outages:** Maintenance outages will occasionally be required on the Wires Owner's distribution system and the (DG Owner's) facilities. Both parties are required to provide as much notice as possible and plan to minimize downtime. It is recognized that in some emergency cases, such notice may not be possible. Outages shall be coordinated by the Operators in Charge of the respective facilities.
8. **Access:** The Wires Owner shall have access to the (DG Owner's) facilities for maintenance, operating and meter reading purposes. The Wires Owner may inspect the (DG Owner's) facilities, and (the DG Owner) may inspect the Wires Owner's facilities. Access or inspections shall be arranged by the Operators in Charge of the respective facilities.
9. **Revision and Approval:** This Agreement does not expire. Either party may cancel the Agreement with reason, after giving notice to the Operating Authority designated by the other party.

APPROVED by:

Wires Owner Operating Authority

DG Owner Operating Authority

Date

Date

Appendix D: Information Provided by Wires Owner

After receiving the application for interconnection, the Wires Owner must provide the following information to the DG Owner, on request:

1. Single Line Diagram or maps of the distribution system to the Point of Common Coupling (PCC).
2. Minimum and maximum 60 Hz source impedances (positive-sequence, negative-sequence and zero-sequence) at the PCC.
3. Maximum and minimum normal and emergency system operating voltage ranges at the PCC.
4. Harmonic impedance envelope at the PCC.
5. Planning, operating and reliability criteria, standards and policies.
6. The results of a planning study documenting the availability of the requested amount of system capacity.
7. Cost estimates and time schedule to build the upstream facilities.
8. Clearing and reclosing times for single-phase and multiple-phase faults occurring on the distribution system.
9. Characteristics and settings of protection on the distribution system.
10. Costs of studies and any required changes to the distribution system.

Some or all of this information will be required by the DG Owner to properly design the interconnection protection. The Wires Owner will identify when the costs of producing this information are to be assigned to the DG Owner.

Appendix E: Applicable Codes and Standards

The distributed generation (DG) and interconnection facilities must conform to this Guide and to the applicable sections of the codes and standards listed below. When the stated version of the code or standard is superseded by an approved revision, then that revision shall apply.

Specific types of interconnection schemes, DG technologies, and distribution systems may be subject to additional requirements, standards, recommended practices or guidelines external to this Guide. Determining the applicability and hierarchy of those requirements in relation to the requirements herein is beyond the scope of this Guide. Therefore, the following list of codes and standards is not to be regarded as all-inclusive, and users of this Guide must address related concerns.

Power Quality Standards

1. ANSI C84.1-1989 American National Standards for Electric Power Systems and Equipment Ratings (60 Hertz). Establishes nominal voltage ratings and operating tolerances for 60 Hz electric power systems from 100 V through 230 kV.
2. IEEE Std. 493-1900 IEEE Recommended Practice for Design of Reliable Industrial and Commercial Power Systems (IEEE Gold Book). Chapter 9 deals specifically with voltage sag analysis and methods of reporting sag characteristics graphically and statistically.
3. IEEE Std 519-1992 IEEE Recommended Practice and Requirements for Harmonic Control in Electric Power Systems.
4. IEEE Std. 1100-1992 IEEE Recommended Practice for Powering and Grounding Sensitive Electronic Equipment (IEEE Emerald Book).
5. IEEE Std 1159-1995 IEEE Recommended Practice for Monitoring Electric Power Quality.
6. IEEE Std 1250-1995 IEEE Guide for Service to Equipment Sensitive to Momentary Voltage Disturbances.

In addition to the power quality standards, the following standards are applicable to the interconnection of generation facilities to the Wires Owner's distribution system:

7. IEEE Std. 100 - 1997 IEEE Standard Dictionary of Electrical and Electronics Terms.
8. IEEE Std 315-1975 (Reaffirmed 1993) ANSI Y32.3-1975 (Reaffirmed 1989) CSA Z99-1975 Graphic Symbols for Electrical and Electronics Diagrams (including Reference Designation Letters).
9. IEEE Std 929-1988 IEEE Recommended Practice for Utility Interface of Residential and Intermediate Photovoltaic (PV) Systems.
10. C37.1 ANSI/IEEE Standard Definitions, Specifications and Analysis of Systems Used for Supervisory Control, Data Acquisition and Automatic Control.
11. C37.2 IEEE Standard Electrical Power System Device Function Numbers.
12. C37.18 ANSI/IEEE Standard Enclosed Field Discharge Circuit Breakers for Rotating Electric Machinery.
13. C37.20.1 ANSI/IEEE Standard for Metal-Enclosed Low-Voltage Power Circuit Breakers Switchgear.
14. C37.20.3 ANSI/IEEE Standard for Metal-Enclosed Interrupter Switchgear.
15. C37.24 ANSI/IEEE Standard for Radiation on Outdoor Metal-Enclosed Switchgear.
16. C37.27 ANSI/IEEE Standard Application Guide for Low-Voltage AC Non-integrally Fused Power Circuit Breakers (Using Separately Mounted Current-Limiting Fuses).

Appendices

17. C37.29 ANSI/IEEE Standard for Low-Voltage AC Power Circuit Protectors Used in Enclosures.
18. C37.50 ANSI Standard Test Procedures for Low-Voltage AC Circuit Breakers Use In Enclosures.
19. C37.51 ANSI Standard Conformance Test Procedure for Metal Enclosed Low-Voltage AC Power Circuit-Breaker Switchgear Assemblies.
20. C37.52 ANSI Standard Test Procedures for Low-Voltage AC Power Circuit Protectors Used in Enclosures.
21. C57.12 IEEE Standard General Requirements for Liquid Immersed Distribution, Power and Regulating Transformers.
22. C57.12.13 Conformance Requirements for Liquid Filled Transformers Used in Unit Installations including Unit Substations.
23. C57.13.1 IEEE Guide for Field Testing of Relaying Current Transformers.
24. C57.13.2 IEEE Standard Conformance Test Procedures for Instrument Transformers.
25. C37.58 ANSI Standard Conformance Test Procedures for Indoor AC Medium-Voltage Switches for Use in Metal-Enclosed Switchgear.
26. C37.90 ANSI/IEEE Standard for Relays and Relay Systems Associated with Electric Power Apparatus.
27. C37.90.1 ANSI/IEEE Standard Surge Withstand Capability (SWC) Tests for Protective Relays and Relay Systems.
28. C37.90.2 ANSI/IEEE Standard Withstand Capability of Relay Systems to Radiated Electromagnetic Interference from Transceivers.
29. C37.95 IEEE Guide for Protective Relaying of Utility Consumer Interconnections.
30. C37.98 ANSI/IEEE Standard for Seismic Testing of Relays.
31. IEC 1000-3-3 Limitation of Voltage Fluctuations and Flicker in Low-Voltage Supply Systems for Equipment with Rated Current Less than 16A.
32. IEC1000-3-5 Limitation of Voltage Fluctuations and Flicker in Low-Voltage Supply Systems for Equipment with Rated Current Greater than 16A.
33. UL1008 Transfer Switch Equipment.
34. IEEE P1547, DRAFT Standard for Distributed Resources Interconnected with Electric Power Systems. Canadian Electrical Code, CSA no. C22-1, latest version.C22.2 No. 31- M89 (R1995) Switchgear Assemblies.
35. Can/CSA - C22.2 No. 107.1-95 Commercial and Industrial Power Supplies.
36. Can/CSA - C22.2 No. 1010.1-92 Safety Requirements For Electrical Equipment for Measurement, Control and Laboratory Use.
37. Can/CSA - C22.2 No. 144-M91 (R1997) Ground Fault Circuit Interrupters.
38. C22.2 No. 193-M1983 (R1992) High-Voltage Full-Load Interrupter Switches.
39. C22.2 No. 201-M1984 (R1992) Metal Enclosed High-Voltage Busways.
40. C22.2 No. 229-M1988 (R1994) Switching and Metering Centres.
41. CSA Standard CAN3 C235 83 Preferred Voltage Levels for AC Systems 0 to 50,000V.
42. Alberta Electrical and Communication Utility Code (formerly the Alberta Electrical and Communication Utility System Regulation 44/1976 or future amendments).
43. Measurement System Standard / Transmission Administrator Metering Standard GC301 Practices for Management and Transfer of Metered Data.
44. C37.04-1999 IEEE Standard Rating Structure for AC High-Voltage Circuit Breakers Rated on a Symmetrical Current Basis (ANSI/DoD).

Appendices

45. C37.06-1997 American National Standard for Switchgear--AC High-Voltage Circuit Breakers Rated on a Symmetrical Current Basis--Preferred Ratings and Related Required Capabilities.
46. C37.09-1999 IEEE Standard Test Procedure for AC High-Voltage Circuit Breakers Rated on a Symmetrical Current Basis (ANSI/DoD).
47. C37.010-1999 IEEE Application Guide for AC High-Voltage Circuit Breakers Rated on a Symmetrical Current Basis.
48. C37.011-1994 IEEE Application Guide for Transient Recovery Voltage for AC High-Voltage Circuit Breakers Rated on a Symmetrical Current Basis.
49. C37.012-1979 (R1988) IEEE Application Guide for Capacitance Current Switching for AC High-Voltage Circuit Breakers Rated on a Symmetrical Current Basis.
50. C37.013-1997 IEEE Standard for AC High-Voltage Generator Circuit Breaker Rated on a Symmetrical Current Basis.
51. C37.015-1993 IEEE Application Guide for Shunt Reactor Switching.
52. C37.081-1981 (Reaff 1988) Guide for Synthetic Fault Testing of AC High-Voltage Circuit Breakers Rated on a Symmetrical Current Basis.
53. C37.11-1997 IEEE Standard Requirements for Electrical Control for High-Voltage Circuit Breakers Rated on A Symmetrical Current Basis.
54. C37.13-1990 (R1995) IEEE Standard for Low-Voltage AC Power Circuit Breakers Used in Enclosures.
55. C37.14-1992 IEEE Standard for Low-Voltage DC Power Circuit Breakers Used in Enclosures.
56. C37.16-1997 American National Standard for Switchgear - Low-Voltage Power Circuit Breakers and AC Power Circuit Protectors-- Preferred Ratings, Related Requirements, and Application Recommendations.
57. C37.20.2-1999 IEEE Standard for Metal-Clad and Station-Type Cubicle Switchgear.
58. C37.23-1987 (R1991) IEEE Standard for Metal-Enclosed Bus and Calculating Losses in Isolated-Phase Bus.
59. C37.30-1997 IEEE Standard Requirements for High-Voltage Switches.
60. C37.32-1996 American National Standard for Switchgear--High-Voltage Air Switches, Bus Supports, and Switch Accessories--Schedules of Preferred Ratings, Manufacturing Specifications, and Application Guide.
61. C37.34-1994 IEEE Standard Test Code for High-Voltage Air Switches.
62. C37.35-1995 IEEE Guide for the Application, Installation, Operation, and Maintenance of High-Voltage Air Disconnecting and Load Interrupter Switches.
63. C37.36b-1990 IEEE Guide to Current Interruption with Horn-Gap Air Switches.
64. C37.37-1996 IEEE Standard for Loading Guide for AC High-Voltage Air Switches (in Excess of 1000 V).
65. C37.38-1989 IEEE Standard for Gas-Insulated, Metal-Enclosed Disconnecting, Interrupter, and Grounding Switches.
66. C37.42-1996 American National Standard for Switchgear--Distribution Cutouts and Fuse Links—Specifications.
67. C37.44-1981 (R1987) American National Standard Specifications for Distribution Oil Cutouts and Fuse Links.
68. C37.54-1996 American National Standard for Switchgear--Indoor Alternating-Current High-Voltage Circuit Breakers Applied as Removable Elements in Metal-Enclosed Switchgear Assemblies--Conformance Test Procedures.
69. C37.55-1989 American National Standard for Switchgear--Metal-Clad Switchgear Assemblies--Conformance Test Procedures.

Appendices

70. C37.57-1990 American National for Switchgear--Metal-Enclosed Interrupter Switchgear Assemblies--Conformance Testing.
71. C37.66-1969 (Reaff 1988) American National Standard for Requirements for Oil-Filled Capacitor Switches for Alternating-Current Systems.
72. C37.81-1989 (R1992) IEEE Guide for Seismic Qualification of Class 1E Metal-Enclosed Power Switchgear Assemblies.
73. C37.85-1989 (R1998) American National Standard for Switchgear--Alternating-Current High-Voltage Power Vacuum Interrupters-Safety Requirements for X-Radiation Limits.
74. ANSI/IEEE C37.90-1989 Surge Withstand And Fast Transient Tests.
75. 120-1989 (Reaff-1997) IEEE Master Test Guide for Electrical Measurements in Power Circuits.
76. 1291-1993 IEEE Guide for Partial Discharge Measurement in Power Switchgear.
77. IEEE Std C62.23-1995 Application Guide for Surge Protection of Electric Generating Plants.
78. ANSI /IEEE C62.41-1991 Recommended Practices on Surge Voltages in Low-Voltage AC Power Circuits.
79. C57.13-1993 IEEE Standard Requirements for Instrument Transformers.
80. C57.13.3-1983 (R1991) IEEE Guide for the Grounding of Instrument Transformer Secondary Circuits and Cases.
81. C57.98-1993 IEEE Guide for Transformer Impulse Tests.
82. C57.19.100-1995 (R1997) IEEE Guide for Application of Power Apparatus Bushings.
83. C57.110-1986 (R1992) IEEE Recommended Practice for Establishing Transformer Capability When Supplying Nonsinusoidal Load Currents.
84. C62.92.4-1991 IEEE Guide for the Application of Neutral Grounding in Electrical Utility Systems, Part IV – Distribution.
85. IEEE Std 242-1986 Recommended Practice for Protection and Coordination of Industrial and Commercial Power Systems.
86. ANSI C12.20 Electricity Meters 0.2 And 0.5 Accuracy Classes.
87. ANSI C62.1 Surge Arresters for AC Power Circuits.
88. ANSI C62.11 Metal-Oxide Surge Arresters for AC Power Circuits.
89. NEMA CC-1 Electric Power Connectors for Substations.
90. NEMA LA-1 Surge Arresters.
91. NEMA MG-1 Motors.

Appendix F: Single Line Diagram for Wye-Delta Interconnection

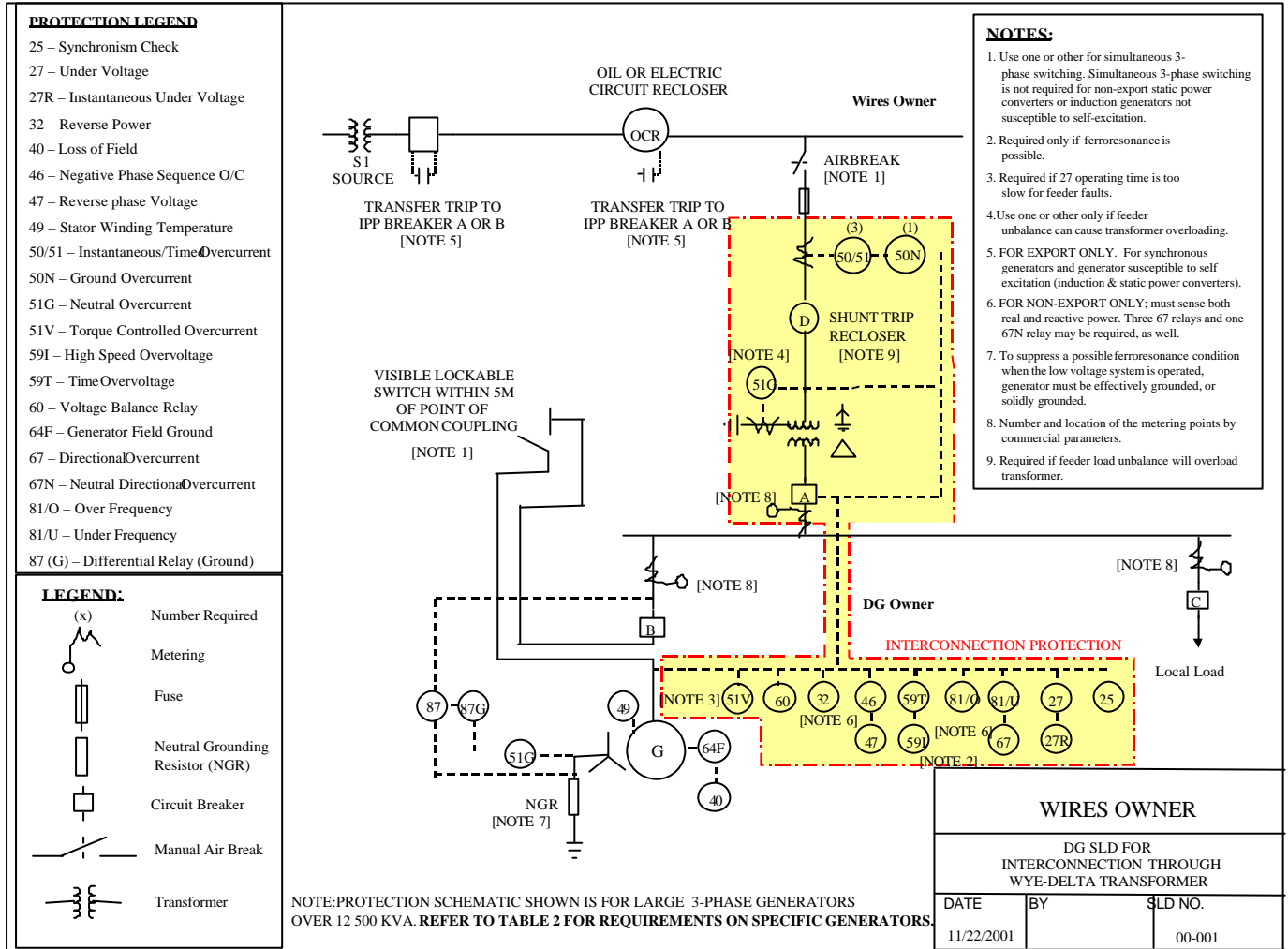

Appendix G: Single Line Diagram For Wye-Wye Interconnection

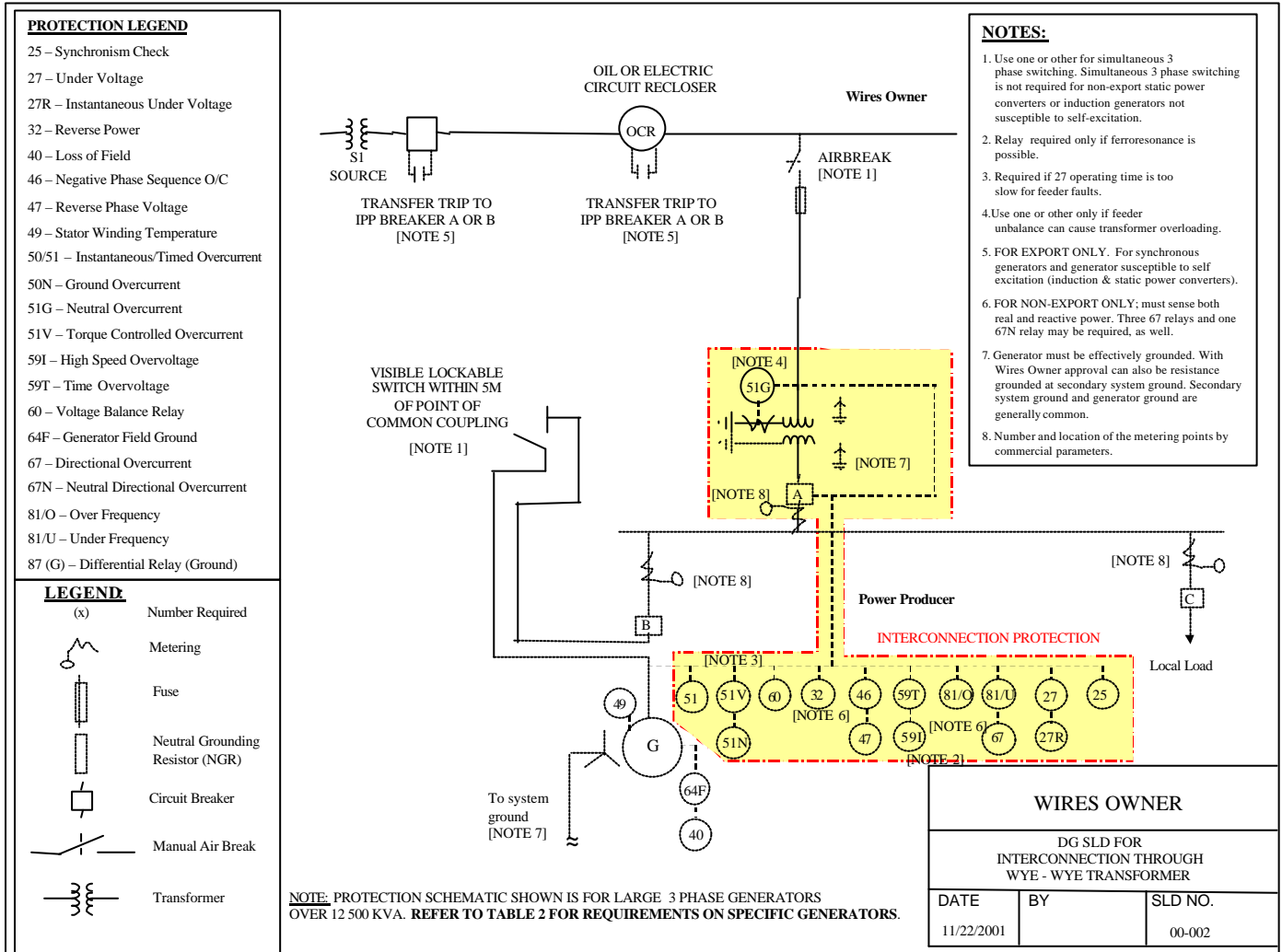

Appendix H: Protective Settings Commissioning Document

PROTECTIVE SETTINGS COMMISSIONING DOCUMENT												
(Set applicable protection to the most conservative values or as agreed to by the Wires Owner)												
OVER VOLTAGE PROTECTION PARAMETERS												
	Phase Voltage to Trip						Duration to Trip					
	GUIDELINE LIMIT	ADJUSTABLE RANGE	AS.SET	TESTED			GUIDELINE LIMIT	ADJUSTABLE RANGE	AS.SET	TESTED		
				A	B	C				A	B	C
Primary Trip δ - N	106% to 120% 1% Increments						30 Cycles					
Fast Trip δ - N	144% to 120% 1% Increments						100ms					
UNDER VOLTAGE PROTECTION PARAMETERS												
	Phase Voltage to Trip						Duration to Trip					
	GUIDELINE LIMIT	ADJUSTABLE RANGE	AS.SET	TESTED			GUIDELINE LIMIT	ADJUSTABLE RANGE	AS.SET	TESTED		
				A	B	C				A	B	C
Primary Trip δ - N	50% to 90% 1% Increments						120 Cycles					
Fast Trip δ - N	Less than 50% 1% Increments						100ms					
NON ISLANDING FUNCTION TEST												
Loss of Utility Voltage							100ms					
Generator Restart Delay after Utility Voltage Failure							5 min Minimum					
Dead Bus Test							Fail to Start Successful (Y or N)					
OVER FREQUENCY PROTECTION PARAMETERS												
	Frequency to Trip						Duration to Trip					
	GUIDELINE LIMIT	ADJUSTABLE RANGE	AS.SET	TESTED			GUIDELINE LIMIT	ADJUSTABLE RANGE	AS.SET	TESTED		
				A	B	C				A	B	C
Primary Trip	60.5 to 61.5 Hz 1% Increments						3 minutes					
Fast Trip	61.5 to 61.7 Hz 1% Increments						30 seconds					
UNDER FREQUENCY PROTECTION PARAMETERS												
	Frequency to Trip						Duration to Trip					
	GUIDELINE LIMIT	ADJUSTABLE RANGE	AS.SET	TESTED			GUIDELINE LIMIT	ADJUSTABLE RANGE	AS.SET	TESTED		
				A	B	C				A	B	C
Primary Trip	59.5 to 58.5 Hz 1% Increments						3 minutes					
Second Trip	58.5 to 57.9 Hz 1% Increments						30 seconds					
Third Trip	57.9 to 57.4 Hz 1% Increments						7.5 seconds					
Fourth Trip	57.4 to 56.9 Hz 1% Increments						45 cycles					
Fifth Trip	56.9 to 56.5 Hz 1% Increments						7.2 cycles					
Fast Trip	Less than 56.4 Hz						100 ms					

Appendix H: Protective Settings Commissioning Document (continued)

REVERSE AC CURRENT PROTECTION FUNCTION												
	Current to Trip						Duration to Trip					
	DESIGN LIMIT	ADJUSTABLE RANGE	AS SET	TESTED			DESIGN VALUE	ADJUSTABLE RANGE	AS SET	TESTED		
				A	B	C				A	B	C
Primary Trip												

SYNCHRONIZATION LIMITS FOR SYNCHRONOUS GENERATORS			
	GUIDELINE LIMIT	ADJUSTABLE RANGE	AS SET
Frequency Difference	+ 0.2 Hz		
Voltage Difference	5%		
Phase difference	10 Deg		

WIRES PHASE & GROUND FAULT PROTECTION FUNCTION												
	Maximum Current or Volts to Trip						Duration to Trip					
	GUIDELINE LIMIT	ADJUSTABLE RANGE	AS SET	TESTED			GUIDELINE LIMIT	ADJUSTABLE RANGE	AS SET	TESTED		
				A	B	C				A	B	C
Phase Current							200 ms					
Neutral Current							200 ms					

TRANSFER TRIP PROTECTION			
	GUIDELINE LIMIT	ADJUSTABLE RANGE	AS SET
Generator Lockout	0.6 seconds		
Fail Safe Lockout	6 seconds		

TEST CERTIFICATION AND HISTORICAL DATA			
TYPE OF TEST			
	ORIGINAL COMMISSIONING TEST	PROTECTION SYSTEM RE-TEST	
DATE OF TEST			
WIRES OWNER REPRESENTATIVE		DG OWNER REPRESENTATIVE	
TITLE		TITLE	
DATE		GENERATOR LOCATION & IDENTIFICATION NUMBER	

Appendix H: Protective Settings Commissioning Document (continued)

Note 1:

- Refer to Chapter 11, "Connecting Small Generators to Utility Distribution Systems," by A. B. Sturton.
- Refer to "Transformer Concepts and Application Course Notes," by Power Technologies Inc., Schenectady, New York.
- Refer to "Electrical Transients in Power Systems," by Allan Greenwood.
- Refer to "Electrical Transmission & Distribution Reference Book," by Westinghouse.

Note 2:

- Refer to "Protective Relaying, Principles and Applications," by J. Lewis Blackburn for details on sub-synchronous resonance.
- Refer to "Electrical Transmission & Distribution Reference Book," by Westinghouse.

Note 3:

- Refer to Chapter 8, "Harmonic and Resonant Effects on Application of Capacitors, Distribution Systems, Electric Utility Reference Book," by Westinghouse.
- Refer to Chapters 11 & 12, "Connecting Small Generators to Utility Distribution Systems," by A. B. Sturton.
- Refer to Chapter 10, "Electric Power Systems: Switching Surges - Interruption of Capacitive Circuits," by B. M. Weedy.

Note 4:

- Refer to Chapter 4, "Connecting Small Generators to Utility Distribution Systems," by A. B. Sturton.

Appendix I: Accuracy Schedules for Metering Equipment

Schedule 1: Non-Dispensated Metering Equipment

Schedule Of Accuracies For Metering Equipment Approved Under Section 9(1) Of The Electricity and Gas Inspection Act

Metering Point Capacity (MVA)	Wathour Meter Accuracy Class	Varhour Meter Accuracy Class	Measurement Transformers Accuracy Class
10 and Above	0.2%	0.5%	0.3%
Below 10	0.5%	1.0%	0.3%

Notes:

1. This schedule applies to requirements set out in Part 2, Section 5.0 of this Guide.
2. If an alternate measurement is used to determine reactive energy, the accuracy class of the alternate measurement must be equal to or better than the accuracy class set out for reactive energy.

Schedule 2: Dispensated Metering Equipment

Schedule Of Accuracies For Meters Approved Under Section 9(2) Or 9(3) Of The Electricity And Gas Inspection Act

Meter Accuracy		
Metering Point (MVA)	Points of Delivery	Points of Supply
10 and Above	1.0 %	1.0 %
Below 10	1.0 %	1.0 %

Notes:

1. This schedule applies to requirements set out in Part 2, Section 5.0 of this Guide.
2. If an alternate measurement is used to determine reactive energy, the accuracy class of the alternate measurement must be equal to or better than the accuracy class set out for reactive energy.